

YORK STREET GARAGE  
240 York Street  
Hanover, - Penna.

Nothing says Quality like the 1960 De Soto



## The car you will either own or envy

You know quality when you see it or De Soto wouldn't interest you in the first place. Quality styling, quality engineering, quality construction. These assure a long and trouble-free life . . . give more value now, more resale value later. The first time you drive a 1960 De Soto, you will discover these things in rare abundance.

Fleetwing styling—a totally new look inside and out . . . a look that stamps you as a person of discernment and good taste. The new Unibody which combines frame and body into one single solid piece of steel. The improvement Unibody makes in ride and handling must be experienced to be believed.

Torsion-Aire Ride—refined to cushion the car better, with no sacrifice of roadability. Insulation has been thickened and extended. Sealing is stronger and tighter. The car's silence is amazing. But only when you drive it will you understand this fact: even at super-highway speeds, you ride in hushed quiet, protected from road shock and noise by the finest combination of body, suspension and insulation ever engineered.

There are six new De Soto models for '60, in the three most wanted body styles (lower priced than last year in every model)! Sixteen exterior solid colors and one hundred twenty combinations are available.

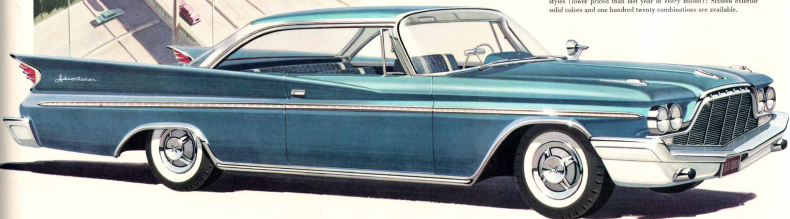

Adventurer 2-door hardtop

If you're going places, this is the car to get you there!  
Its styling is rich with the flair of youth . . . the verve of the sportsman.  
This car says you enjoy the finest things in life.  
Yet every line of its design serves a purpose and does it beautifully!

## Adventurer 4-door hardtop

You demand a distinctive automobile that still is easy to get in and out of and has room for the entire family. You demand the Adventurer 4-door hardtop! It has inches more room inside (as much room as the 4-door sedan!) and all the glamour of the magic name "Adventurer."



### Adventurer 4-door sedan

Never before available in the Adventurer line! Here is the perfect blending of sedan convenience and Adventurer luxury... smartly conservative. Best of all, it's priced lower than any Adventurer in years! You may pick your power plant from three great new Adventurer engines.

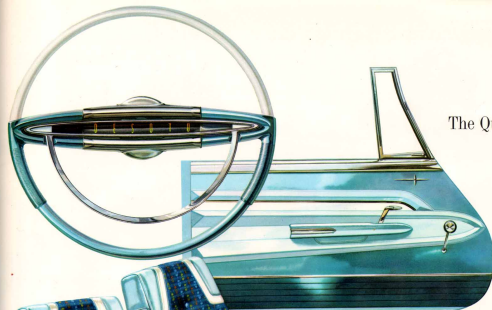

### The Quality speaks for Itself . . .

And, perhaps most eloquently of all, inside the passenger compartment. Example: the back of the driver's seat is a full 5-inches higher, giving you greatly increased comfort and support. You drive hours longer and still feel fresh. (And the entire seat can now be custom-adjusted by your dealer to fit you.) Example: roomier dimensions now make possible a completely natural sitting position for the driver and all passengers in both seats. Feet are flat on the floor. Knees are level with hips. You sit relaxed on heavy foam padding. Example: rich new fabrics of contemporary design are perfectly color keyed to each other and to the exterior color of the car. Special nylon threads help them wear longer. Both fabric and vinyl wipe clean with a damp cloth. Example: an instrument panel that is as functional as it is beautiful. Modern, attractive controls and indicators, grouped where you can see them instantly and reach them safely.

Quality starts in the mind of a man at a drawing board. It takes form in the hands of a craftsman. It comes full circle anywhere you look in the 1960 DeSoto.



### Firelite 2-door hardtop

This year it's possible to own the most distinguished Firelite of all at a new lower price! If your taste in motorcars craves an action automobile at a more modest price, this smart 2-door hardtop is your car. The Adventurer Mark I engine is also available on this Firelite.



Firelite 4-door hardtop

When you take delivery of this great new style leader, you know you are providing your family with the ultimate in safe, secure motoring as well as beautiful design. Compared with its 1959 counterpart, its bumper-to-bumper length is less than last year, yet it has inches more room inside!



Firelite 4-door sedan

There is more true value than ever in this brilliant new Firelite... yet it is priced significantly lower than any Firelite in recent memory. This is the finest in a generation of fine cars... and still this new 4-door sedan is the lowest priced 1960 DeSoto of all!

## The stronger, quieter DeSoto Unibody... most significant quality advance in a decade

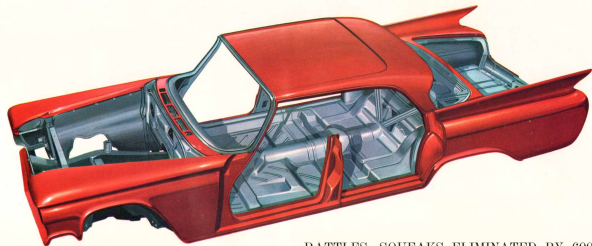

### RATTLES, SQUEAKS ELIMINATED BY 6000 WELDS

Engineers have known for years the virtues of unit-body construction. With frame and body a single unit, rattle-causing nuts, bolts and washers could be eliminated... frame side rails could disappear with no loss of protection... interior roominess, comfort and roadability could all be greatly increased. Perhaps most important of all, a welded single-piece body-frame unit resulted in tremendously increased strength for the entire car. And the car stayed strong, silent and rattle-free for years. It was a better, safer car when it was new and for as long as anyone would drive it.

It took years of research and development to make such a system both practical and acceptable to the tough quality standards of Chrysler Corporation engineers. For 1960, DeSoto introduces the Unibody, exclusive in our price class. It has 40% greater resistance to up-and-down stresses and 100% greater resistance to twist. It is everything we hoped for—and more!

### Now... a ride never before available at any price

You will notice the difference the moment the car begins to move. There is a new sureness and steadiness. You will feel the great strength and safety in the firm, solid way it smooths the bumps—the flat, ground-gripping way it glides around sharp curves. Unibody has helped make this possible—but it's more than that... it's Unibody in combination with Torsion-Aire Ride that has worked this miracle.

Other cars (mostly small cars) have unit bodies. Other cars (mostly European cars) have torsion bar suspension. But only DeSoto is in its field combines Unibody, torsion bars and extended rear leaf springs to bring you a totally new experience in automobile riding... a ride you couldn't have had before at any price. You simply must drive the new DeSoto to appreciate it.

### More good news about the unitized body

Head room and leg room have both been increased. This alone would make the car more comfortable. But that's only part of the story. The additional room has allowed us to make your seating posture more natural and more comfortable.

To make getting in and out easier than ever, door pillars have been redesigned and repositioned, and the doors open wider.

Some of our engineers think the thing you'll notice most in the '60 DeSoto is the almost complete lack of noise, even at cruising speeds. The new Unibody itself plays a part in this, along with more insulation in more places which is now possible with Unibody. This is important to you for more reasons than you may think. It is a fact that noise is nerve-racking. Noise from the

engine and the road in an ordinary car is one of the most important causes of fatigue. The lack of noise in a 1960 DeSoto means you can drive further and arrive feeling fresher.

Tighter sealing of windows and doors is now possible, to keep your new DeSoto warmer in winter and dry in the most driving rain. Seals and weatherstripping have been improved in quality, too. And Unibody is easier to inspect, simpler to repair. This saves you time and money.

Protection against rust and corrosion has been revolutionized. Each underbody is dipped seven times in rustproofing chemicals and protective coatings. This means longer life for your new DeSoto.

Feature for feature, the 1960 DeSoto Unibody offers you a new quality combination that simply cannot be equaled. And it's standard equipment on every new DeSoto at no extra cost.

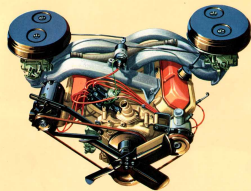

#### RAM CHARGE ENGINE

For brilliant responsiveness in the middle-speed range and safer highway passing, De Soto offers the Ram Charge engine . . . an entirely new concept for a passenger car.

The ram induction principle utilized in this engine is based on developments proved in years of Chrysler Corporation engineering research and in supercharged racing cars. It literally rams air and fuel into the cylinders when you need maximum performance. Yet, unlike conventional superchargers, there are no complicated moving parts. This new high-performance engine has two four-barrel carburetors and special "tuned" manifold pipes which create a compressor-like effect.

The De Soto Ram Charge engine is a limited production option, available at extra cost on Adventurer models only.

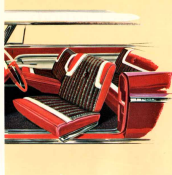

#### AUTOMATIC SWIVEL SEATS

Now more convenient than ever, De Soto swivel seats are completely automatic. Open the door and the seat swivels out to greet you, automatically. Close the door and it swivels back in place. Of course the seat remains stationary if someone is sitting on it when the door is opened or closed. (If you think you can catch it, just try!) Automatic swivel seats also available with 6-way power control.

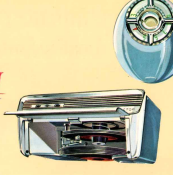

#### ULTRA-FI RECORD CHANGER

Built by RCA, De Soto's new automatic record changer plays all standard 45 rpm records through the car's radio amplifier and speaker system, lets you enjoy up to two hours of high-fidelity music. Load or unload it with one hand, as easily as opening or closing a drawer.



#### THREE-WAY AUTO-PILOT

Let us set the speed you want to drive on the highway and maintain that speed even on hills (a toe touch on the brake disengages it). OR . . . you can pre-set the maximum speed you wish to drive in the city and Auto-Pilot warns you when that speed is reached.



#### 4-SEASON AIR CONDITIONING

Touch a button for spring-like weather the year 'round. High capacity unit (entirely under the hood so it takes up no foot room) heats in winter, cools in summer, removes excess moisture as well as dirt, dust and pollen from incoming air. Improved efficiency at all speeds.



#### TRANSAUDIO RADIO

As new as 1960, this powerful 5 1/2-watt transistorized receiver has greater signal sensitivity than ever. Transistors replace bulky tubes and won't burn out! Push-button operated. Rear seat speaker and dual rear fender antennas also available.



#### AUTOMATIC BEAM CHANGER

Electronically lowers your headlights when a car approaches (or when you get close behind the car ahead), raises them after it's past. Lets you see better because it remembers to turn on your bright lights instantly every time you should see them.

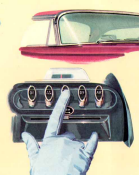

#### PUSH-BUTTON HEATER

More efficient than ever, just touch a button to turn on or off, select blower speeds, control vent and defrosting — easy as changing stations on your car radio. For night driving, buttons are lighted from within. Horizontal lever controls temperature.

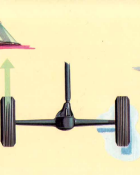

#### SOLEX GLASS

Soft tinted Solex glass filters out harsh sun glare, eases eyestrain but doesn't disturb nighttime visibility. Filters out heat rays to help keep you cooler in summer. Graduated tint (darker at the top) included in both windshield and large rear window.



#### SURE-GRIP DIFFERENTIAL

As long as either one of your rear wheels has traction, you'll never get stuck in snow, ice or mud. Sure-Grip differential transfers power from the slipping wheel to the wheel that has traction so no power is lost . . . gets you on your way in a hurry!



#### DUAL-JET WINDSHIELD WASHERS

Now, push-button convenience extends to the windshield wipers, too! Fully automatic, just touch the convenient dash control (no need to hold it), washers (and wipers) go to work, clean the windshield, shut themselves off when they're through!

Nothing says quality and convenience like De Soto optional equipment



#### PUSH-BUTTON TRANSMISSIONS

Choose either 3-speed Torqueflite (standard on all Adventurer models) or 2-speed Powerflite. Both are push-button operated, proved in millions of miles of driving. Both offer quick, smooth performance and a driving range equal to any situation.

#### CONSTANT CONTROL POWER STEERING

Possibly the greatest driving work-saver ever invented. Reduces steering effort about 90%! You can literally park with one finger and concentrate on where the car is going because you needn't "fight" the wheel. Gives you better control on the road, too.

#### TOTAL CONTACT POWER BRAKES

Just the touch of your toe brings the car to a safe, sure, straight-line stop. A particularly desirable option for women and younger drivers because power brakes are so effortless to use. They're safer, too, because they can be applied more quickly.

#### POWER WINDOWS

Touch a button and the windows go up or down . . . smoothly, quickly, electrically. A master control panel lets you operate any window in the car from the driver's seat. A separate control button is also located below each window. The last word in convenience!

#### 6-WAY POWER SEAT

One knob lets you select the most comfortable seat position for you. The seat moves up, down, forward, back, left toward or away from the wheel. You can change seat positions safely even while the car is moving. Available with regular seats or swivel seats.

#### REMOTE CONTROL OUTSIDE MIRROR

Mounted far forward so you can see behind and ahead at the same time, it is fully adjustable from inside the car — a big safety factor when both husband and wife drive and need different mirror settings. Handy new stick control makes adjustment easier.



#### 3-WAY PRISMATIC MIRROR

Adjusts with a touch for (1) daytime driving (2) normal nighttime driving or (3) nighttime driving with bright lights behind you. OE-center dash mounting makes it easier to reach, does not obstruct windshield, lets you see farther back on the road behind.



#### DUAL-SPEED REAR WINDOW DEFOGGER

New two-speed blower unit lets you select the amount of air you need for the weather conditions. Mounted out of sight behind the package shelf, blower melts winter ice and snow quickly, prevents window from steaming up on warm, humid days.



#### DUAL-TONE REAR SEAT SPEAKER

Dual-tone speaker (1) provides easier listening for rear-seat passengers without turning the radio on too loud for folks in the front seat (2) combines with instrument-panel speaker to form a two-speaker "hi-fi" system for rich, full-fidelity sound.

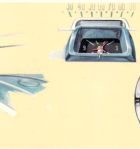

#### ELECTRIC CLOCK

De Soto's electric clock is located in the instrument cluster so the driver can see it at a glance, almost without taking his eyes from the road. Neatly styled, this new clock keeps excellent time because it's precision-built and self-adjusting whenever reset.



#### STAINLESS STEEL WHEEL COVERS

Stainless steel for durability, chrome "finned" for added luster, newly styled for that dash of elegance. Standard on all Adventurer models, their small extra cost on a FireLite is well repaid in the perfect finishing touch they add to your new car.

#### OTHER DESIRABLE ACCESSORIES

A number of other fine De Soto accessories are available to make your driving more pleasant and convenient. Some of the more popular ones are:

- POWER-OPERATED RADIO ANTENNA
- MIRROR-MATIC "ELECTRIC EYE" REAR VIEW MIRROR
- VACUUM DOOR LOCKS
- TRIAD HORN
- TINTED PLEXIGLASS SUN VISORS
- SUN VISOR SAFETY PADS
- DOOR EDGE PROTECTORS
- SPOTLIGHTS
- UNDER HOOD LIGHTS
- CURB SIGNALS
- GAS TANK CAP WITH LOCK
- FRONT AND REAR CARPET PROTECTORS



# 1960 DE SOTO

## *Accessory Groups*

To make it easier for you to order the optional equipment you want, De Soto has assembled a number of accessory GROUPS. Each group is made up of accessories that normally go together and that most DeSoto buyers like to order as a unit.

### ADVENTURER GROUPS

#### BASIC GROUP No. 1 (Code 305)

HEATER  
RADIO  
POWER STEERING  
POWER BRAKES  
DUAL JET WINDSHIELD WASHER  
PARKING BRAKE LIGHT  
ELECTRIC CLOCK  
3-WAY PRISMATIC MIRROR  
VANITY MIRROR  
LICENSE PLATE FRAME  
OUTSIDE REAR VIEW MIRROR  
(left side)

#### BASIC GROUP No. 2 (Code 306)

This group is identical to *Adventurer Basic Group No. 1*, except that it includes a *Remote Control Outside Rear View Mirror* in place of the ordinary *Outside Rear View Mirror*.

---

### FIREFLITE GROUPS

#### BASIC GROUP (Code 301)

WHEEL COVERS  
DUAL JET WINDSHIELD WASHER  
VARIABLE SPEED WINDSHIELD WIPERS  
3-WAY PRISMATIC MIRROR  
EASY GRIP PLASTIC STEERING WHEEL

#### CONVENIENCE GROUP (Code 302)

This group includes all the items in the *Fireflite Basic Group plus:*

HEATER  
RADIO  
SAFETY PADDED INSTRUMENT PANEL  
VANITY MIRROR  
LICENSE PLATE FRAME

#### POWER GROUP No. 1 (Code 303)

This group includes all the items in the *Fireflite Basic and Convenience groups plus:*

POWER STEERING  
POWER BRAKES  
ELECTRIC CLOCK  
BUMPER GUARDS  
OUTSIDE REAR VIEW MIRROR  
(left side)

#### POWER GROUP No. 2 (Code 304)

This group is identical to *Fireflite Power Group No. 1*, except that it includes a *Remote Control Outside Rear View Mirror* in place of the ordinary *Outside Rear View Mirror*.

#### LIGHT PACKAGE (Code 371)

GLOVE BOX LIGHT  
TRUNK LIGHT  
ASH TRAY LIGHT  
MAP LIGHT  
BACK-UP LIGHTS  
PARKING BRAKE LIGHT

# 1960 DE SOTO

## *Optional Exterior Trim*

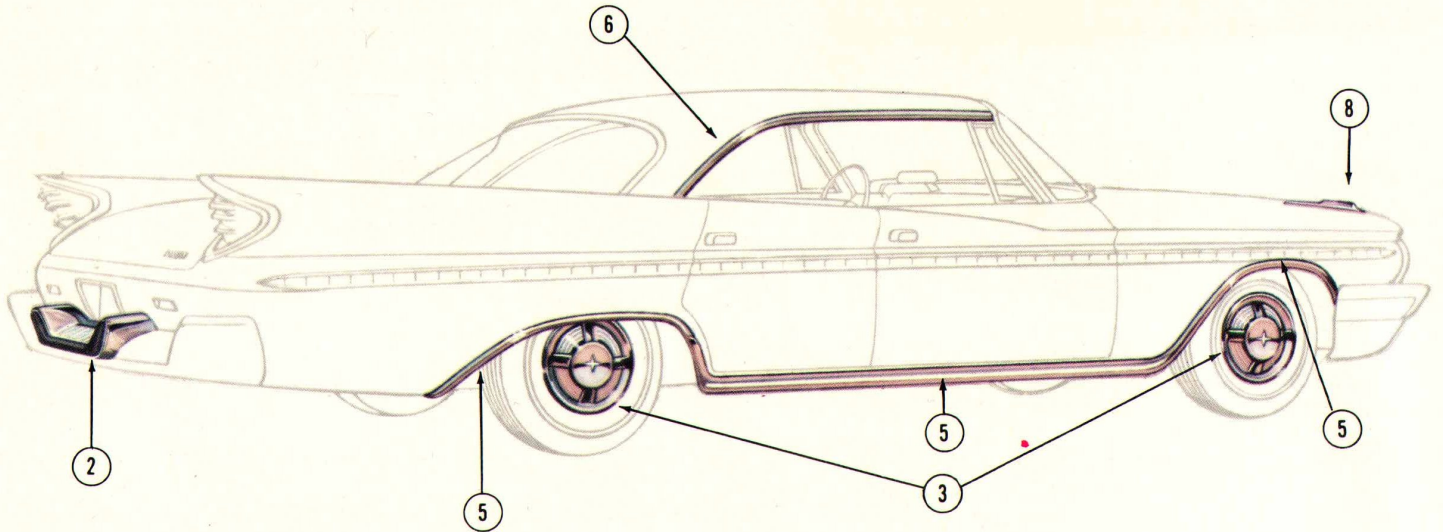

- ① LICENSE PLATE FRAME.
- ② BUMPER GUARDS (Standard on Adventurer).
- ③ WHEEL COVERS (Standard on Adventurer).
- ④ STONE DEFLECTORS (Fireflite only).

- ⑤ SILL AND WHEELHOUSE MOULDINGS WITH STONE DEFLECTORS (Standard on Adventurer).
- ⑥ 4-DOOR ROOF MOULDING PACKAGE (Standard on Adventurer).
- ⑦ 2-DOOR ROOF MOULDING PACKAGE (Standard on Adventurer).
- ⑧ FRONT FENDER ORNAMENT.

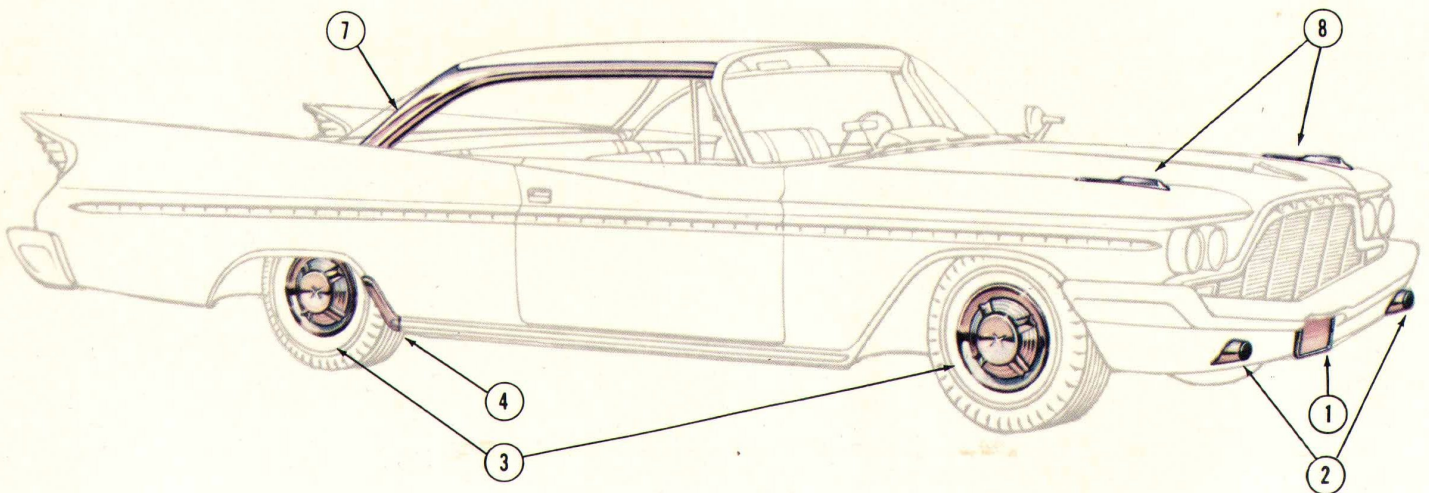

Your new De Soto can be even more attractive with the addition of selected exterior trim. These styling accents will add to your pleasure in owning a 1960 De Soto—and at surprisingly low cost.





## 4 reasons why you must *drive* the 1960 DeSoto

No single component alone is responsible for the thrilling performance of the 1960 DeSoto. There are dozens—perhaps hundreds—of precision mechanisms working together every time you press the accelerator. Of these many parts and systems, *four* are of special interest:

**1. Torsion-Aire Ride.** The torsion-bar suspension system has been used for some years on racing cars and on many European sports cars because it is ideal for safe handling on bad roads, around sharp turns, and for fast stops. First brought to U.S. motorists three years ago, Torsion-Aire Ride has been refined and improved each year. It maintains a clear superiority over old-fashioned coil spring systems. It is the most rugged suspension system on any high-performance automobile. And it's exclusive on DeSoto in its field. Torsion-Aire makes your DeSoto corner flat and steady, free from lean or sway . . . makes it stop straight without nose dive . . . start without rear-end dip. And for your own personal comfort, it is the most luxurious ride in any automobile at any price.

**2. High-Performance Engines.** DeSoto's rugged, precision-built engines range the high-performance spectrum. You may choose the Turboflash, Adventurer, Adventurer Mark I, or the mighty Ram Charge Engine. Each has been quality-engineered for a particular purpose. Each combines a high degree of performance and economy. All 1960 DeSoto engines have a new steel spring rear mount which greatly reduces engine noise and vibration.

**3. Torqueflite Transmission.** Proved dependable in action, DeSoto's three-speed Torqueflite automatic transmission converts engine power into "go" power at the touch of a button—quickly, efficiently, and more smoothly than ever before. Gives you the "jump" you need for entering fast-moving traffic and more flexible operation in congested city driving.

**4. Rear Axle Ratios.** DeSoto offers you a choice of two axle ratios—a "high-performance" ratio and an "economy" ratio. You can order the rear axle ratio that fits your kind of driving best.

### 1960 DeSoto Specifications

#### Engines

**TURBOFLASH** (standard all Fireflite models): 8 cylinder, 90 degree V. Valves inclined, in line overhead; intake valve diameter, 1.95"; exhaust valve diameter, 1.60"; bore and stroke, 4.125" x 3.375"; compression ratio, 10 to 1; displacement, 361 cu. in.; 2-barrel carburetor, standard equipment. Taxable hp, 54.4. Premium fuel recommended.

**ADVENTURER** (standard all Adventurer models): 8 cylinder, 90 degree V. Valves inclined, in line overhead; intake valve diameter, 2.08"; exhaust valve diameter, 1.60"; bore and stroke, 4.250" x 3.375"; compression ratio, 10.1 to 1; displacement, 383 cu. in.; 2-barrel carburetor, standard equipment. Taxable hp, 57.8. Premium fuel recommended.

**ADVENTURER MARK I** (optional, all Adventurer and Fireflite models): Same as Adventurer, with 4-barrel carburetor.

**POWER CHARGE** (optional, all Adventurer models): same as Adventurer, with cross-over ram-induction manifold, dual 4-barrel carburetors, high-performance camshaft and distributor.

#### Transmissions

**SYNCHROMESH** (available on special request only, Fireflite models only): 3-speed manual shift; 3-speeds forward and 1 reverse; synchro-silent all-helical gears; single plate dry ventilated clutch. Ratios: first, 2.12; second, 1.43; third, 1.00; reverse, 2.73.

**POWERFLITE** (optional, all Fireflite models): 2-speed fully automatic transmission, hydraulically actuated; combines torque converter with planetary gears. Ratios: starting, 1.72; drive range (low), 1.72; drive range (direct), 1.00; reverse, 2.39. Control by manually operated pushbuttons (4) mounted on instrument panel.

**TORQUEFLITE** (standard, all Adventurer models; optional, all Fireflite models): 3-speed fully automatic transmission, hydraulically actuated; combines torque converter with planetary gears. Ratios: starting, 2.45; drive range (low), 2.45; drive range (second), 1.45; drive range (direct), 1.00; reverse, 2.20. Control by manually operated pushbuttons (5) mounted on instrument panel.

#### Lubrication, All Models

Full pressure to main, connecting rod and camshaft bearings. Full-flow oil filter standard.

#### Cooling, All Models

Full-length water jacket, surrounds bores; 4-blade 18" diameter fan; water capacity, 16 quarts (17 quarts with heater).

#### Distributor, All Models

Single breaker type; mechanical and vacuum controlled automatic advance.

#### Rear Axle, All Models

Silent hypoid, semi-floating. TORQUEFLITE: Performance ratio (3.31) or economy ratio (2.93) available at no extra cost. POWERFLITE: Performance ratio (3.31) only.

#### Suspension System, All Models

Torsion-Aire Ride, standard equipment. Combines pre-stressed, tempered steel torsion-bar front suspension with extended-leaf spring rear suspension. Oriflow shock absorbers on all four wheels. Isolated from body by rubber bushings.

#### Body, All Models

Fully welded, integrated construction. Immersion-rustproofed in important underbody areas. Finished with hardening rustproofing process, two primer coats, two Lustr-Bond enamel coats throughout. Fuel tank capacity (all models), 23 gallons.

#### Exterior Dimensions

Wheelbase (all models), 122"; overall length, (all Fireflite models) 215.4"; (all Adventurer models) 217"; overall width (all models), 79.4"; overall height (all 4-door models) 53"; (all 2-door models) 54.8"; front tread (all models), 61"; rear tread (all models), 59.7"; road clearance (all models, with standard load), 6.2".

#### Standard Equipment

**FIREFLITE:** Torsion-Aire Ride, Turboflash V-8 engine, Total Contact brakes, new manually adjustable 6-way front seat, Safety Rim wheels, Oriflow shock absorbers, constant speed electric windshield wipers, front and rear carpets, solenoid shift starter, foam front seat.

**ADVENTURER:** All Fireflite standard equipment (except that Adventurer V-8 engine replaces Turboflash, and variable speed electric windshield wipers replace constant speed), plus; Torqueflite transmission, safety-padded instrument panel, Easy Grip plastic steering wheel, stainless steel wheel covers, bumper guards, roof moldings, back-up lights, foam rear seat, chrome interior garnish moldings, full length sill and wheelhouse moldings, aluminum seat side shields.

**Note:** Manufacturer reserves the right to revise, change or modify construction of DeSoto motor vehicles, or any part thereof, as he may see fit without incurring any obligation to make like changes on vehicles previously sold.