



SERVICE REFERENCE BOOK

119

A LOOK AT 1958 CAR FEATURES"

PREPARED BY CHRYSLER CORPORATION
PLYMOUTH • DODGE • DE SOTO • CHRYSLER • IMPERIAL

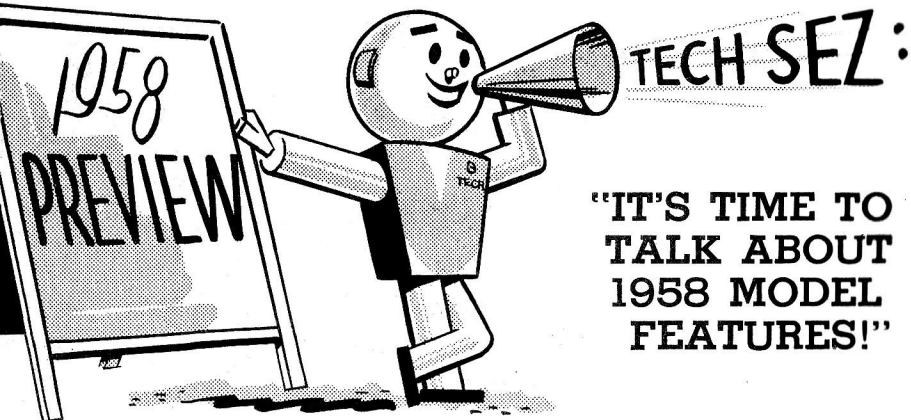

**"IT'S TIME TO
TALK ABOUT
1958 MODEL
FEATURES!"**

Here's your introduction to 1958 model features – and a swell chance to get advance information *before* the new cars come in for service.

Keeping up-to-date – or even ahead of the parade whenever possible – is the mark of all up-and-coming technicians. They know, and you'll agree, that when you can get a head start on what new features are involved along with how service procedures are affected, correct-in any new conditions that may arise is a lot easier.

You'll find this helpful preview on brand-new features arranged as follows:

	<i>Page No.</i>
NEW V-8 ENGINE	3
ENGINE FEATURES	4
FUEL INJECTION	11
CONSTANT-CONTROL POWER STEERING	12
SERVICE OPERATIONS	15
BACKLASH ADJUSTMENT	15
STEERING VALVE ADJUSTMENT	16
POWER STEERING PUMP	18
SURE-GRIP DIFFERENTIAL	18
WATER-COOLED TRANSMISSIONS	20
CARBURETOR – MODEL AFB	21
DUAL HEADLAMPS	22
CONCLUSION	23

NEW V-8 ENGINE

A new V-8 engine makes its bow with the 1958 series. It is an overhead-valve type with a wedge-shaped combustion chamber and hydraulic valve lifters. Compression ratio is 10 to 1, and the engine requires premium fuel. This engine is made in two sizes.

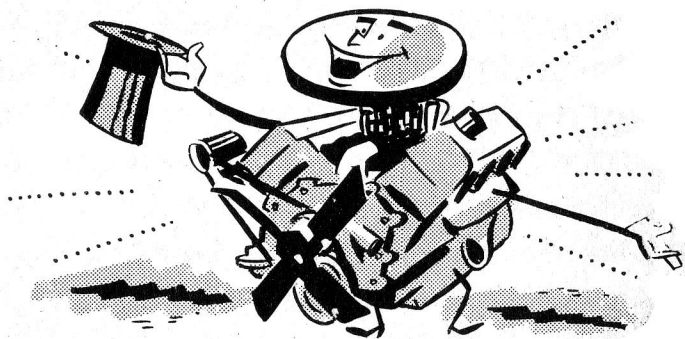

350 CU. IN.

OPTIONAL

• Plymouth

STANDARD

- Dodge Custom Royal and Station Wagons
- De Soto Firesweep

With a bore of 4.0625 in. and a stroke of 3.375 in., giving a displacement of 350 cu. in., this engine is standard equipment in the Dodge Custom Royal series and the Dodge Suburban, Sierra, and Custom Sierra models. Also, it is standard equipment for the De Soto Firesweep series. It is available as optional equipment for all series of the Plymouth line.

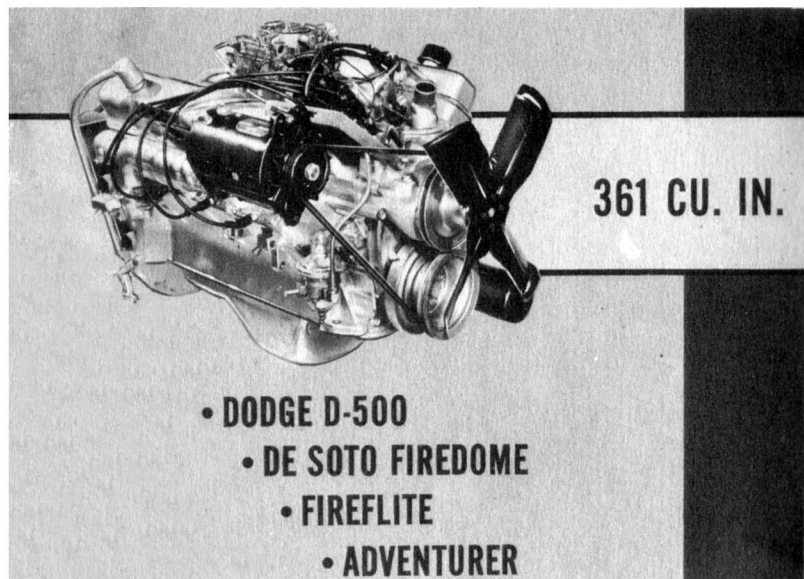

With a bore of 4.125 in. and a stroke of 3.375 in., giving a displacement of 361 cu. in., this engine is standard equipment for the Dodge D-500, and for the De Soto Firedome, Fireflite and Adventurer models.

Engine Features. The cylinder block of this engine is of new design, the sides extending three inches below the crankshaft center line. This provides more rigid support for the crankshaft and for the transmission, and eliminates the need for a torque converter housing adapter plate. The block is recessed at the front to form an integral timing chain case, permitting the use of a stamped rather than a cast chain case cover.

Full-length water jackets surround each cylinder, yet the water capacity has been reduced to improve engine warm-up and to effect a general reduction in weight. A drain plug is located near the front of each bank of cylinders to drain the water jackets.

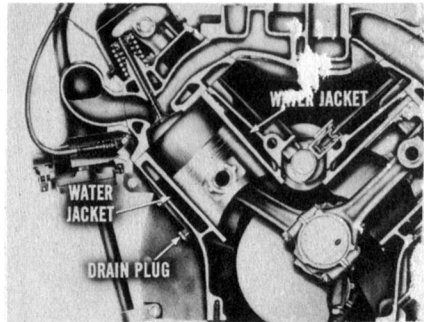

One feature you will certainly like is the new location of the distributor. It is up front, at the right front corner of the engine, where it is easily accessible for service.

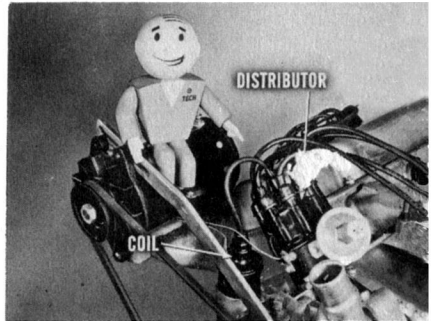

The engine oil pump is externally mounted at the lower left front corner of the engine, and is a rotor-type, full-pressure pump.

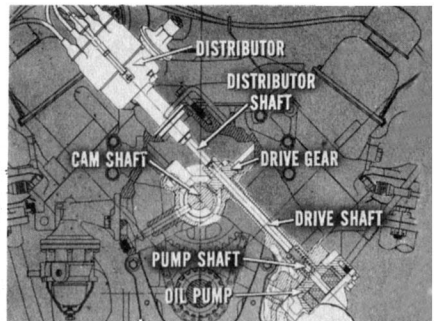

The distributor and the engine oil pump are driven by a diagonally mounted drive shaft which, in turn, is driven by the camshaft.



The oil filter is entirely new. It is a full-flow filter of the disposable type, and is mounted on the front face of the oil pump base. Engine oil capacity is four U.S. quarts. When the filter is changed, an extra quart of oil is required.

On cars driven normally, change oil every 5,000 miles. But on cars operated under other conditions such as dusty areas, or for short trip driving, change oil more often. Each change, if possible should coincide with an oil filter change. Use service MS oil of the viscosity to match the anticipated temperature range.



To replace the filter, unscrew it from the base. If the filter has taken a set on its mounting, it may be necessary to use Oil Filter Removing Wrench, C-3654. Throw away the complete filter and the gasket. Clean the base, install a new gasket and screw the new filter on until the gasket contacts the base. Then tighten the filter *by hand*, turning it about one-half turn after it is snug. Start the engine and check for leaks.



There may be instances where the oil filter may have to be replaced before the 5,000-mile change period. When the engine oil and filter are clean, the oil pressure gauge reading will be fairly high. However, if unusual operating conditions cause the filter to become clogged, oil pressure will gradually show lower readings. This can be used as an indication the oil and filter require changing.

Cylinder heads are made of a chrome-alloy cast iron, resulting in lighter weight. Each head is secured by 17 bolts, insuring a leak-tight joint between the head and block. Valves are arranged in line.

Intake valves are of silicon-chromium steel, while the exhaust valves are of nitrogen-treated Manganese chromium-nickel steel. Valve seat angles are 45 degrees. Valve stem guides are fit in the heads.

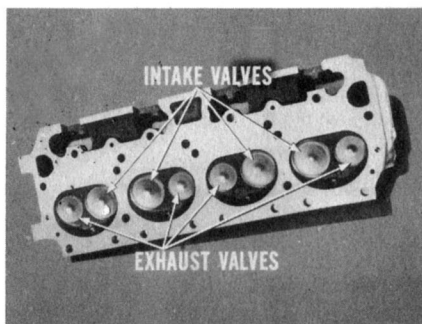

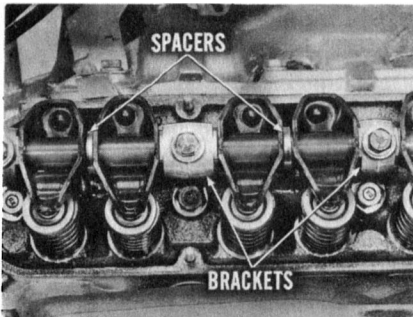

Valve rocker arms are of rigid, lightweight, steel, and are mounted on a single shaft, and pressure-lubricated. Spacers are used between each pair of arms to absorb side thrust resulting from push rod angularity.

Pistons are aluminum alloy, tin-coated. They are partially slotted in the oil control ring groove and are provided with a twist-in steel band, or a steel strut at the pin bosses, to control expansion. Each piston carries two compression and one oil control ring. Pistons are fitted with from .0005 in. to .0015 in. clearance, measured at the top of the skirt. Piston pins are fitted in the piston so they slide through of their own weight at 70 degrees F., and are an "interference" fit in the connecting rod. "Interference" fit means that the broached



hole in the connecting rod is from .0007 in. to .0012 in. under the pin diameter. This method of fitting the piston pins prevents them from floating horizontally, even when hot, and eliminates the need for lock rings in the piston.

A vibration damper is used on the front end of the crankshaft.

Valve lifters, or tappets, are hydraulic. They can be removed from the engine without disturbing the intake manifold or the cylinder heads by using Puller C-3631 inserted through the opening in the cylinder head. Also, the engine oil pan can be removed without having to move the engine.

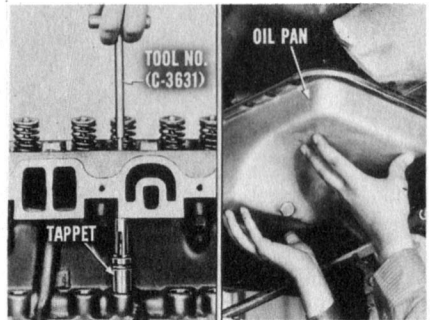

The distributor uses a single set of points except in the case of the Plymouth Fury, Dodge D-500 and the De Soto Adventurer. Those cars use two sets of points. In both distributors the point gap is .015 in. to .018 in.

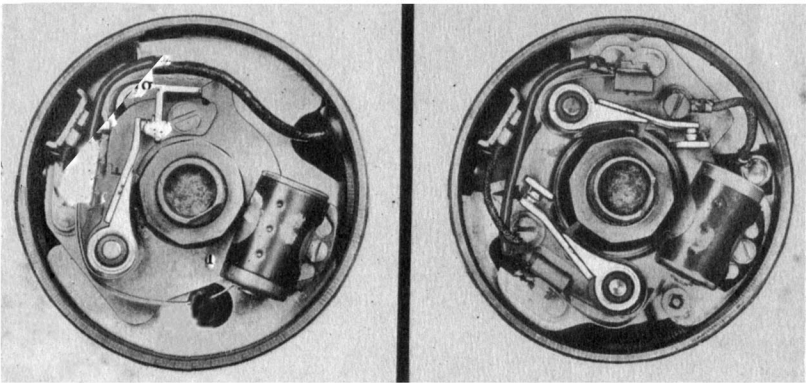

Use a dwell meter to adjust points for best performance. Cam dwell for the single breaker distributor is 29 to 32 degrees; for the double breaker distributor it is 36 to 39 degrees total. Failure to obtain this dwell may indicate a worn rubbing block, a bent point arm, a worn distributor shaft or worn bushings.

With the new compression ratio of 10 to 1, ignition timing is particularly important. Ignition timing is 6 degrees Before Top

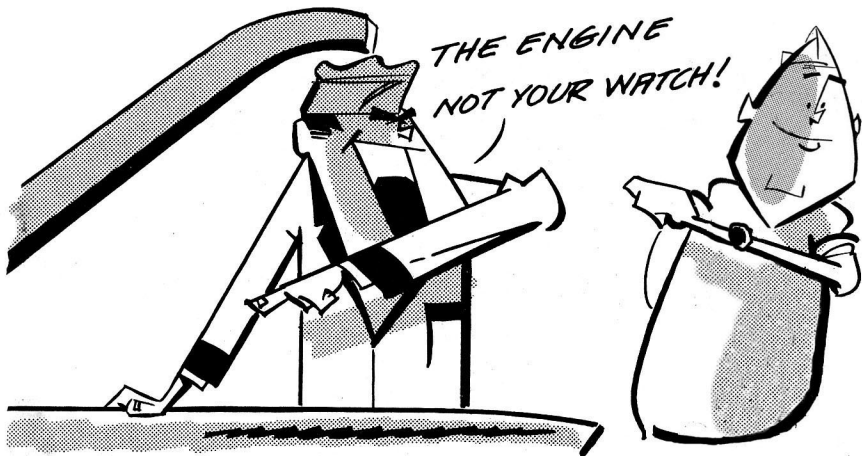

Center, plus or minus 4 degrees. In other words, timing can be set from Top Center to 10 degrees Before, depending upon the type of fuel being used and the operating conditions. Under no circumstances should timing be set higher than 10 degrees BTC due to inaudible preignition that may be encountered while accelerating, resulting in damage to the engine. As mentioned earlier, premium fuel must be used for optimal performance.

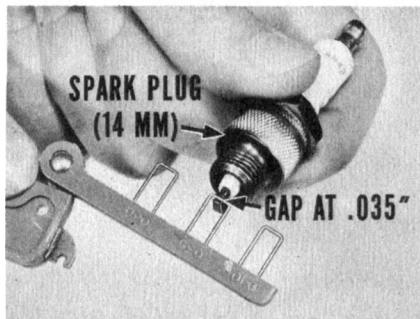
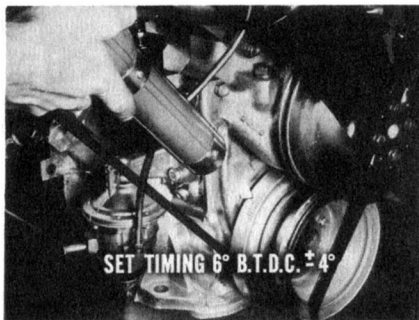

Spark plugs are the 14 mm, AutoLite AR-32 and AR-42, depending on the car model, with a recommended gap of .035 in. measured with a round wire gauge. When installing, use new gaskets and tighten the plugs to 30 ft.-lb. torque.

Note: The Dodge 325-cubic-inch engine has redesigned combustion chambers and uses a long-reach plug, AGR-42.

After the engine has reached normal operating temperature, set the idle speed at 450 to 500 r.p.m.

Don't overlook the operation of the manifold heat control valve. This valve is very important to the performance and economy of the engine. Check the valve each time the car is lubricated or when any work is done under the hood. The valve must be free. If it sticks, lubricate it with the solvent made especially for that purpose.

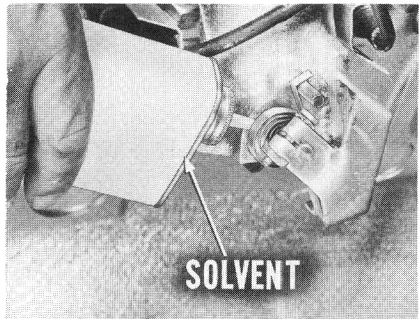

The engine cooling system holds sixteen U. S. quarts of water—seventeen if a hot water heater is used. The 160-degree thermostat is standard for all cars; cars with factory-installed air-conditioning equipment use the 180-degree thermostat as standard equipment. All cars equipped with this new engine have a 14-pound pressure radiator cap.

FUEL INJECTION

Gasoline fuel injection, electronically controlled, will be available as optional equipment on certain models of the 1958 series.

FUEL INJECTION (ELECTRONICALLY CONTROLLED)

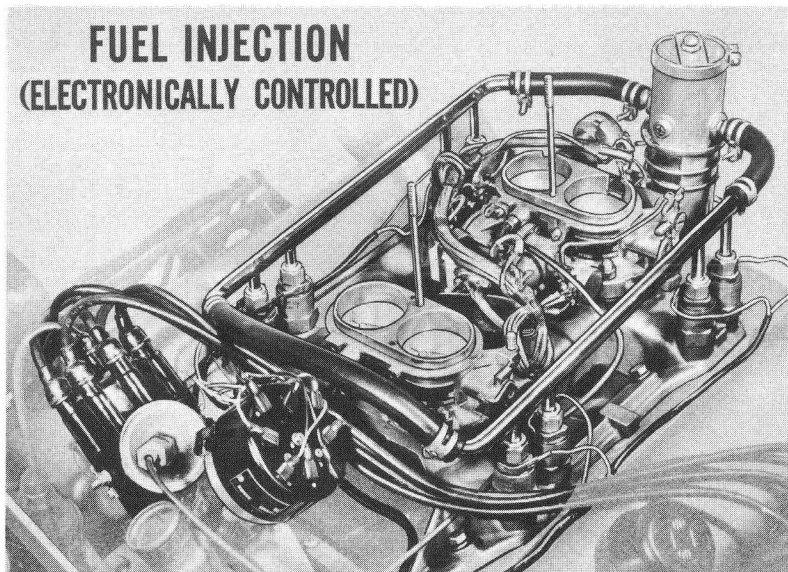

Due to limited availability of fuel injection in 1958, a complete description of the system and how it is serviced will be provided at a later date.

CONSTANT-CONTROL POWER STEERING

Outstanding among the 1958 features is an entirely new hydraulic power steering unit. It is known as the Constant-Control, Full-Time Power Steering Unit.

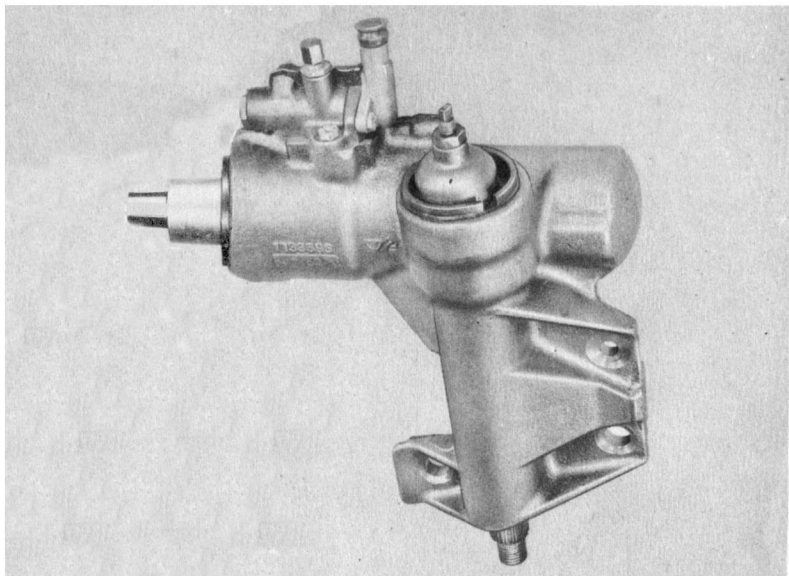

The new unit is very compact, being located entirely within the engine compartment. Along with the new steering unit some models use a new hydraulic pump.

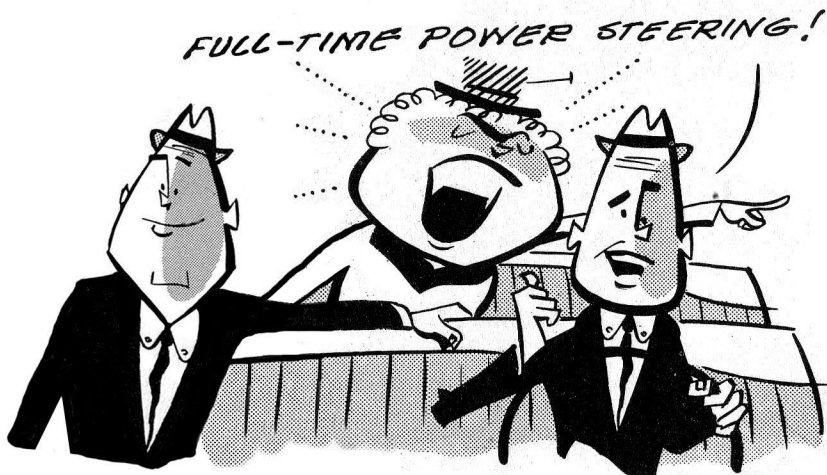

Adjustments of the new power steering unit has been greatly simplified. Mounted on the top of the gear housing is the pressure control valve housing and the steering valve body. The pressure control valve acts as a back-pressure valve. Its application is to hold fluid pressure in the unit at a certain value. It also provides a return passage for the displaced fluid. The steering valve body contains a spool-type steering valve that directs fluid on the piston for a right or left turn.

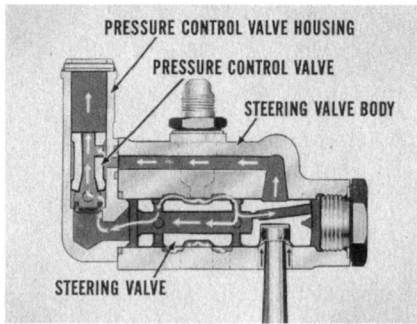

The pressure control valve acts as a back-pressure valve. Its application is to hold fluid pressure in the unit at a certain value. It also provides a return passage for the displaced fluid. The steering valve body contains a spool-type steering valve that directs fluid on the piston for a right or left turn.

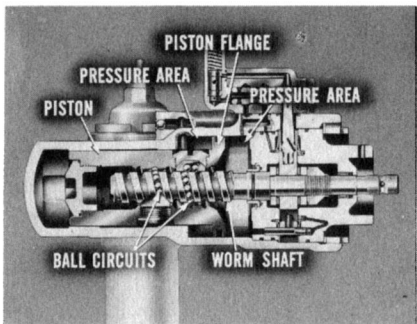

The steering worm shaft operates inside the piston on two ball circuits. The piston travels up and down on the worm shaft. Pressure areas are on each side of the piston flange.

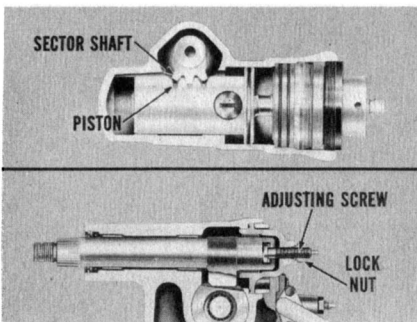

The piston and the sector shaft mesh with rack teeth in the outer surface of the piston. An adjusting screw and lock nut control the backlash between the piston and the sector shaft.

The steering valve is operated by a pivot lever. As the steering wheel turns, there is a slight endwise movement of the worm shaft – just enough to move the lower end of the pivot lever.

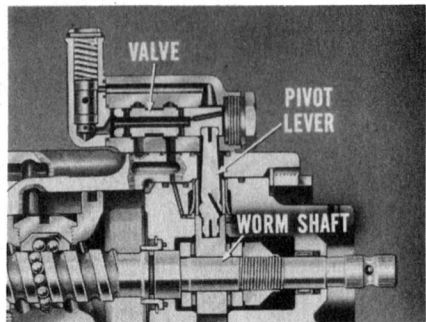

The upper end of the pivot lever moves the steering valve which directs fluid to one side of the piston flange or the other, for a right or left turn.

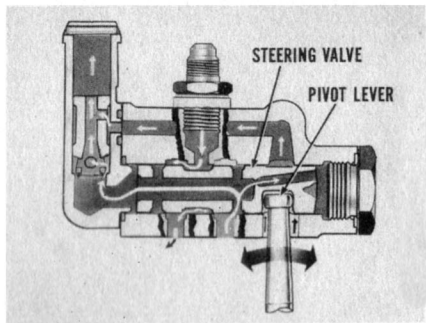

Service Operations. Adjustments to control backlash between the piston and sector shaft, and to control the hydraulic assist in either direction can be made while the unit is installed in the car.

Backlash Adjustment. Backlash adjustment is made by means of the adjusting screw located in the housing cover. With the front wheels straight ahead, turn the adjusting screw out until backlash can be felt. Then, turn the screw IN until backlash disappears.

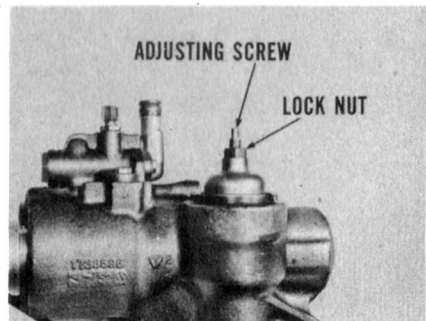

Finally, turn the screw IN from three-eighths to one-half turn more – this will provide the proper preload on the sector teeth. Tighten the adjusting screw lock nut to 50 foot-pounds.

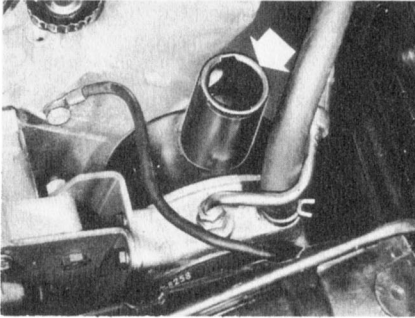

Steering Valve Adjustment. Before you make this adjustment, you should bleed the system to be sure all the air is worked out of the fluid. Here's how it is done. First, remove the cover or filler cap from the reservoir and be sure there is enough fluid in the reservoir. Then, start the engine.

While you are looking into the reservoir, have someone turn the steering wheel from extreme left to extreme right, slowly. Have him keep turning the wheel until no more bubbles appear. Then, add more fluid, if needed, and install the cover or filler cap on the reservoir. You are now ready to proceed with the steering valve adjustment.



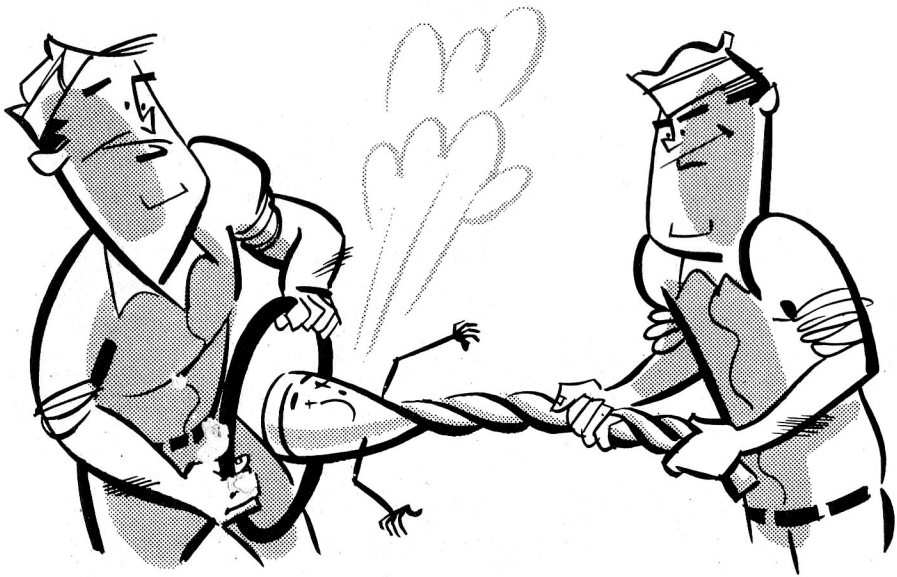

Adjustment to control the indexing of the lands of the steering valve with the right-turn and left-turn ports of the valve body and gear housing is done by moving the steering valve housing position on gear housing. Loosen the valve housing mounting screws, and then tighten them to 7 foot-pounds.

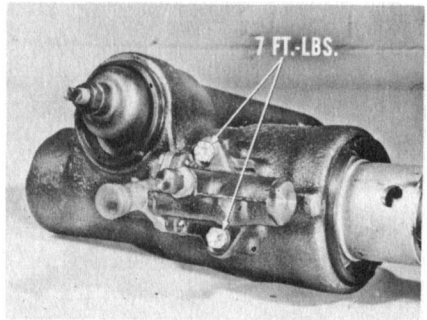

With the engine running, place a torque wrench on the steering gear arm retaining nut and measure the amount of torque required to turn the sector shaft each side of the center or straight-ahead position. Torque should not exceed 20 foot-pounds, and the force required should be equal within five foot-pounds, for each direction. If the force is not equal, or within the five foot-pound limit, it will be necessary to slide the steering valve body up or down, as required.

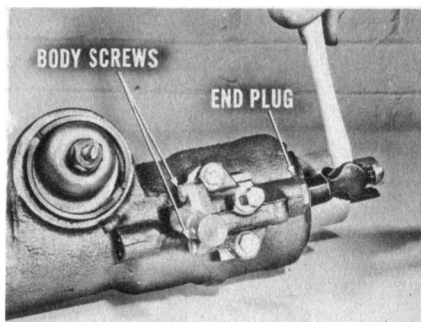

To move the body down – tap lightly on the end plug on the upper end until the valve is centered and the force is within specifications. To move the body up – tap lightly on the two pressure control valve housing screws. When the proper position is obtained, tighten the screws to 15 foot-pounds.

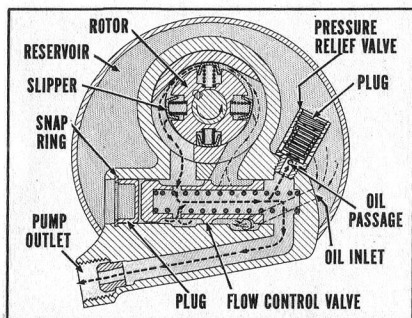

Power Steering Pump. The new power steering pump is mounted on the water pump housing, and is belt driven. It is a constant displacement, slipper-type pump. It is fitted with a flow control valve which permits recirculation of the fluid within the pump and controls the maximum flow at about two gallons per minute.

Maximum pressure output is controlled by the pressure relief valve at 850 to 950 psi.

Service of the pump is limited to replacing the drive pulley, the oil seal, the “O” ring, and the relief valve assembly. Further disassembly of the pump is not recommended.

SURE-GRIP DIFFERENTIAL

A “Sure-Grip” differential is an option available on all 1958 models. This new differential permits power to be directed to the wheel that has the most traction, thus assuring enough pulling power so the car can be driven out of most difficulties easily. Under normal driving conditions the differential operates like the conventional differential.

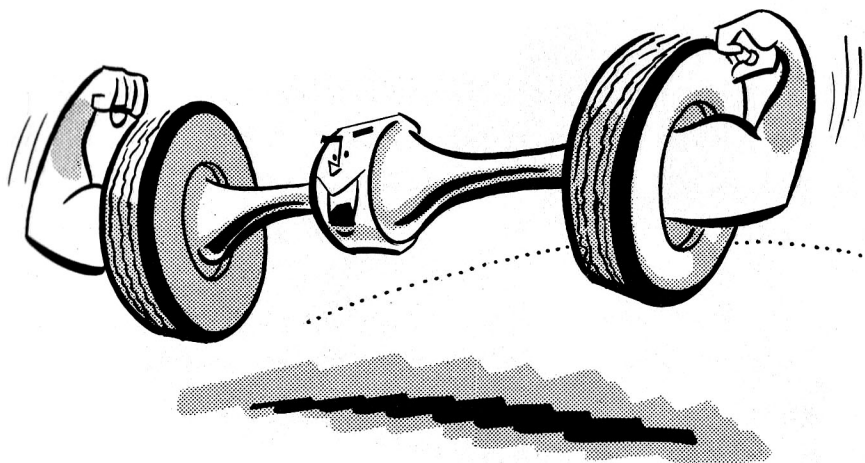

However, when sudden patches of ice, snow, sand or oil slicks are encountered, it will not let the wheel with lesser traction spin, gain momentum and swerve the car when dry pavement is encountered. It accomplishes this by redirecting unused power in the axle whose wheel is free to spin to the other axle whose wheel has the greater friction.

Description. In appearance the “Sure-Grip” differential is similar to that of a conventional differential in all respects but for the addition of friction or clutch plates for clutching the differential case to the axle shafts, and a means for engaging these plates.

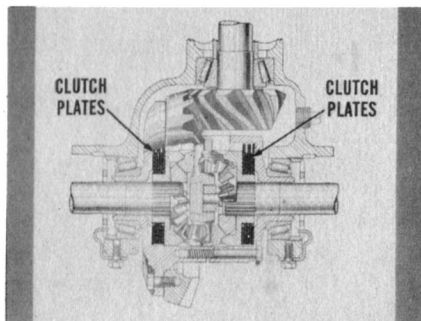

The "Sure-Grip" differential uses four pinions, positioned in the

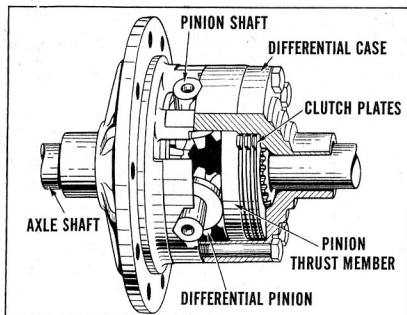

case on two pinion shafts which are perpendicular to each other and loose fitting at their intersection. Steel thrust members are located between the clutch plates and rear face of the gears. Both ends of each shaft have two flat surfaces or ramps which slide on identical ramps in the case.

Lubrication. Because of the use of the friction plates in the new differential, a new special rear axle lubricant is required. This special lubricant cushions the clutch plates against rattle and also provides a better cushion between the gear teeth. The lubricant is available in one-quart cans under part number 1879414. The rear axle capacity is 3½ pints.

More complete information on the "Sure-Grip" differential will be contained in a future session.

WATER-COOLED TRANSMISSIONS

A new method of cooling the transmission fluid is used on some models equipped with PowerFlite and TorqueFlite automatic transmissions.

Cooling the fluid after it leaves the torque converter is accomplished by routing it through an external tube to a coil located in the center of the lower tank of the car's radiator. Heat from the trans-

mission fluid thus is transferred to the engine coolant. From the outlet connection of the coil, the fluid returns by another external tube to the transmission where it begins its circulation cycle. It is important that all tube connections be secured to prevent loss of fluid.

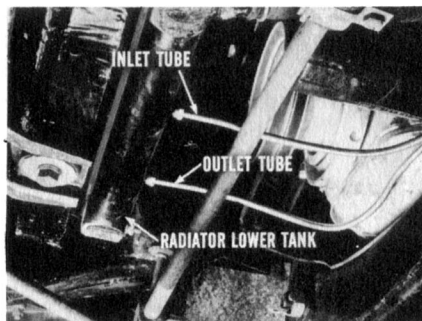

CARBURETOR—MODEL AFB

A new four-barrel carburetor known as model AFB is used on some engines of all models. It is a reduced height unit and contains many new features. One of these is that all major castings are aluminum with the throttle body cast integral with the main body. The carburetors used on Plymouth, Dodge, and De Soto models are equipped with the cross-over type automatic choke. The units on Chrysler and Imperial models use the integral automatic choke.

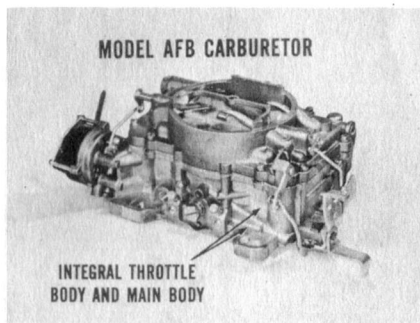

There is also a new location for the step-up rods, pistons and springs which makes them more accessible for service without removing the air horn or removing the carburetor from the engine.

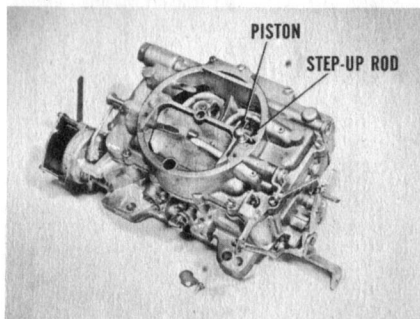

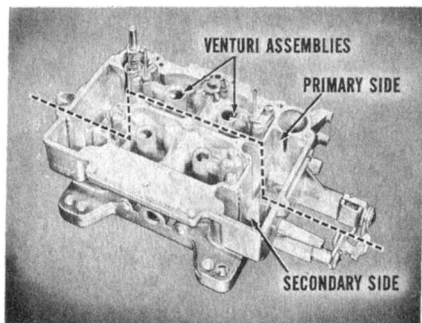

The venturi assemblies, primary and secondary, are replaceable and contain many of the calibration points for both high- and low-speed systems. The section containing the accelerator pump and choke is termed the primary side of the carburetor. The other side is the secondary.

Service procedure on this type carburetor will be contained in a later session.

DUAL HEADLAMPS

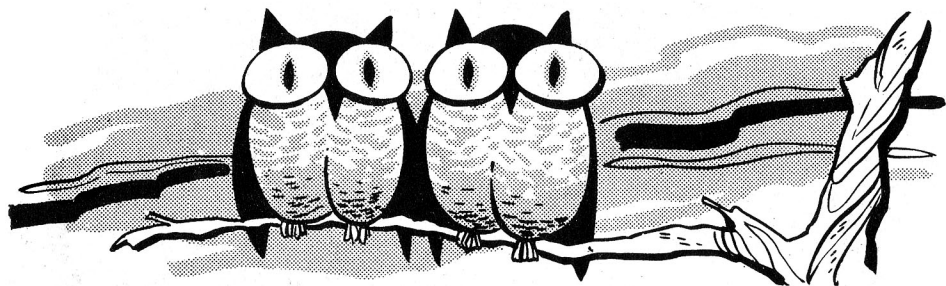

Dual headlamps are standard equipment on all models. The inboard lamps on each side have only single filaments and operate only on the high beam. The outboard lamps on each side have two filaments and work on both high and low beams. These outboard lamps serve as the passing lamp and also supply the fill-in or supplementary light for 'high-beam operation.



The total wattage of the dual headlamps is greater than that of the former single headlamps. To obtain maximum benefits from the increased lighting, it is important that the lamps be properly aimed in accordance with the procedure outlined in MTSC Session No. 107.

CONCLUSION

This preview of the 1958 model features will acquaint you with some of the new units we'll be talking more about during the coming months. The more familiar you become with the design and operation of these units, the more easily you'll understand diagnosis and maintenance procedures coming your way later.

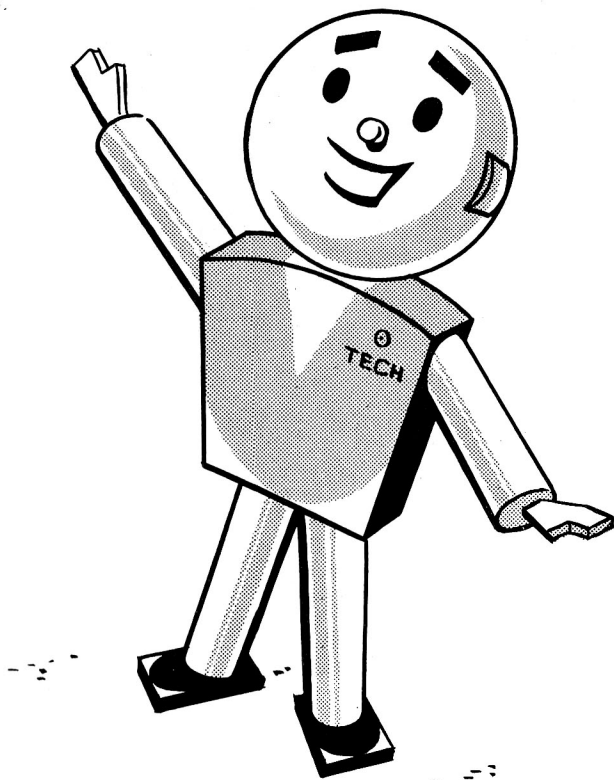

RECORD YOUR ANSWERS TO THESE QUESTIONS ON QUESTIONNAIRE NO. 119

In spite of the high compression ratio of 10 to 1, the newer engines will give equally satisfactory performance with regular or premium grade gasoline.

RIGHT

1

WRONG

"Interference fit" of the piston pin means the pin hole in the rod is from .0007" to .0012" under pin diameter, making it a tight press fit.

RIGHT

2

WRONG

Hydraulic tappets on the new engine can be removed without disturbing the intake manifold or cylinder head, and the oil pan can be removed without moving the engine.

RIGHT

3

WRONG

Set ignition timing at 6 degrees B.T.D.C. plus or minus 4 degrees.

RIGHT

4

WRONG

New engines use type AR-32 and type AR-42 spark plugs with a gap set at .035".

RIGHT

5

WRONG

Operation of the manifold heat control valve on the new engine is not too critical an item.

RIGHT

6

WRONG

Only two external adjustments are required on the new Constant-Control Full-Time power steering gear.

RIGHT

7

WRONG

The Sure-Grip differential is one of the "drive to both wheels" type of differentials.

RIGHT

8

WRONG

Some 1958 automatic transmissions will have external tubes and a coil in the lower radiator tank to cool transmission fluid.

RIGHT

9

WRONG

Some '58 engines will use a new model AFB carburetor, lower in height, with most castings of aluminum, and greater ease of servicing.

RIGHT

10

WRONG