

service reference book no. **120**

Constant-Control **POWER STEERING**

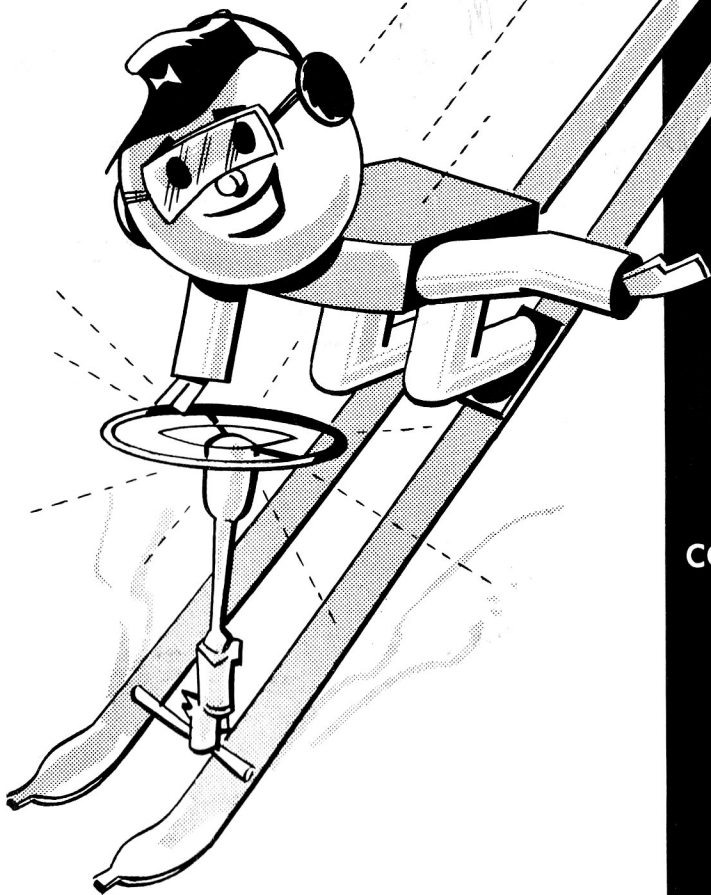

Prepared by
**CHRYSLER
CORPORATION**

Plymouth
Dodge
De Soto
Chrysler
Imperial

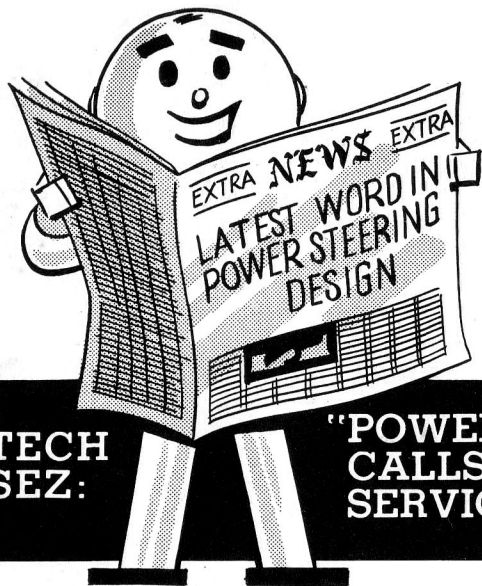

**TECH
SEZ:**

**"POWER STEERING
CALLS FOR GREATER
SERVICE KNOWLEDGE"**

Nobody will deny that it pays to keep up with the newest in power steering units. Anybody can see that power steering is becoming more of a standard item every day. Manual steering may soon become as unusual as manual transmissions.

Our new unit, the Constant-Control, Full-Time Power Steering Gear is the latest word in power steering design. Here's your chance to get well stocked with information you'll need about this newest steering gear. This book spells out the new parts involved, tells how the unit operates, and ends with service procedures that will help you if you have occasion to service the unit.

Here's how this information is arranged for ready reference:

	<i>Page No.</i>
INTRODUCTION	3
DESCRIPTION	4
SECTOR SHAFT	5
WORMSHAFT ASSEMBLY	5
REACTION AREA	7

	Page No.
HYDRAULIC OPERATION	9
NEUTRAL POSITION	9
LEFT TURN	9
RIGHT TURN	10
BACK-PRESSURE CONTROL VALVE	10
REACTION AREA	11
GEAR RESISTS ROAD SHOCK	14
MAINTENANCE	14
TEST PUMP PRESSURE	15
SLIPPER-TYPE PUMP SERVICE	17
STEERING GEAR SERVICE	18
SUMMARY	23

INTRODUCTION

One good way to appreciate the newest in full-time power steering is to drive a car equipped with the unit. You'll soon notice that it offers a constant hydraulic power assist on demand. There's instant response of the front wheels to the slightest turn of the steering wheel.

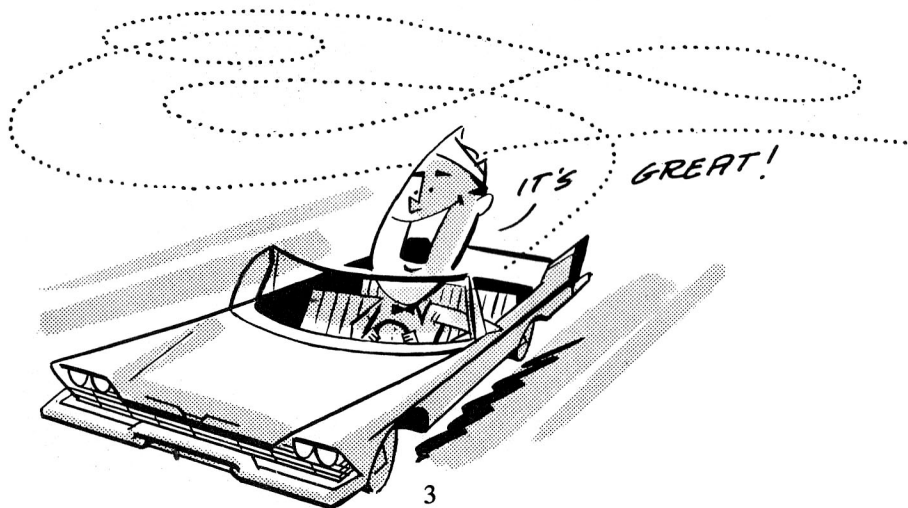

This new Constant-Control gear provides a positive “feel-of-the-road”. You get the feeling that everything is under full control all the time. Directional stability is excellent. It makes car handling a breeze, so customers are bound to be favorably impressed.

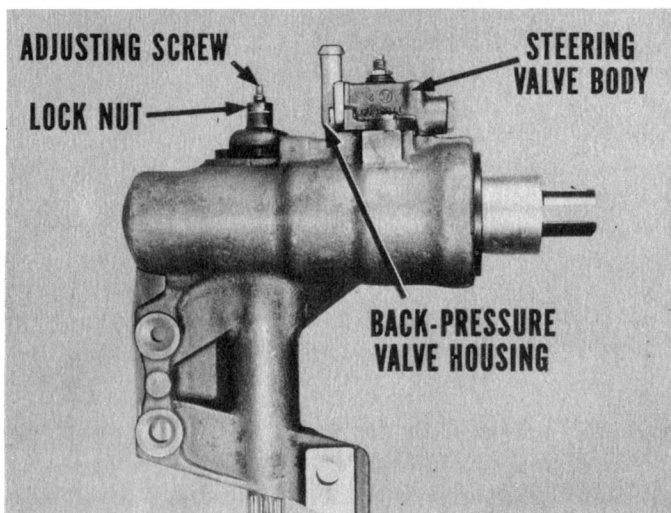

DESCRIPTION

At first glance, this new unit looks smaller than previous power gears you've worked on. It actually is more compact, and fewer parts are involved. Physically, it's a lot easier to handle.

Service adjustments can be made on the outside of the unit while it is still installed in the car. One feature you'll welcome is the ease in reaching the cross shaft adjusting screw and lock nut. Backlash adjustment has been simplified.

Adjustment to equalize power assist has been simplified, too, through the newly designed steering control valve. The steering control valve body is mounted on top of the gear housing. The back-

pressure valve housing is attached to the end of the steering control valve body. You can now shift that valve body position on the gear housing to adjust for equal assist on left and right turns. We'll go into this greater ease of service further after getting better acquainted with all the new parts involved.

Sector Shaft. The Constant-Control gear uses a one-piece housing. The sector shaft is mounted vertically in that housing, and operates on roller bearings. There's one set of roller bearings at the upper end, and two sets below the sector teeth. These bearings are pressure-lubricated by the power steering fluid. A spanner nut secures a cover that holds the sector shaft in the housing.

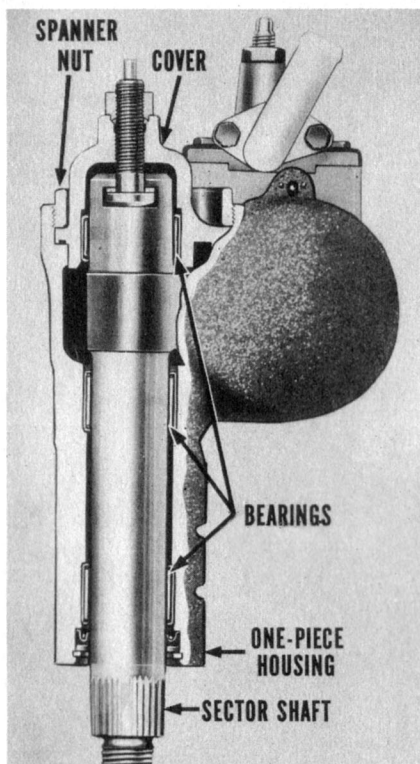

The sector shaft adjusting screw threads through a seal in the cover. A second seal between the cover and housing guards against any possible leakage. A seal and retainer are installed at the lower end of the sector shaft. They're held in by a snap ring.

Wormshaft Assembly. The wormshaft connects the steering wheel to the power unit piston through a flexible coupling. Two recirculating ball circuits gear the wormshaft to the piston. Incidentally, the wormshaft and piston are serviced only as an assembly. The ball bearings in the recirculating circuits are precision-made to a gnat's eyebrow. They are selec-

tively fitted by means of electronic equipment so there will be an absolute minimum of friction and free-play.

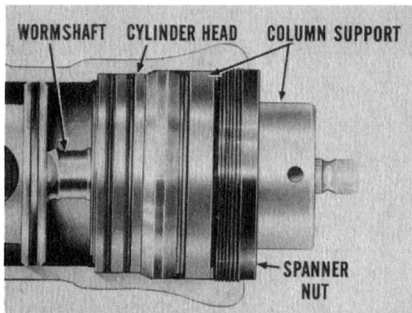
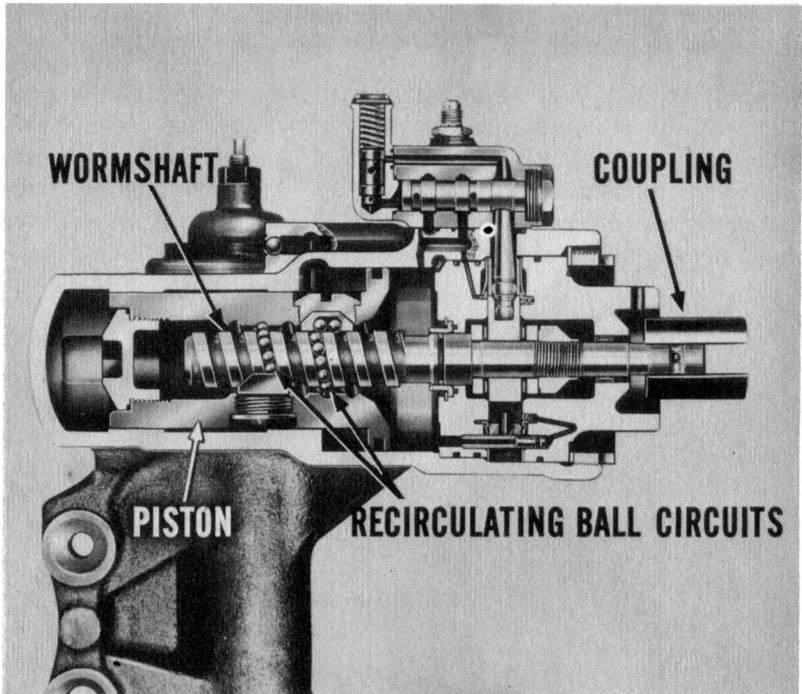

The wormshaft extends through the cylinder head, and through the steering column support at the upper end of the gear housing. A spanner nut holds the column support to the housing.

A roller bearing supports the upper end of the wormshaft in the column support. There is a low-friction seal between the main shaft and cylinder head that is an entirely new idea.

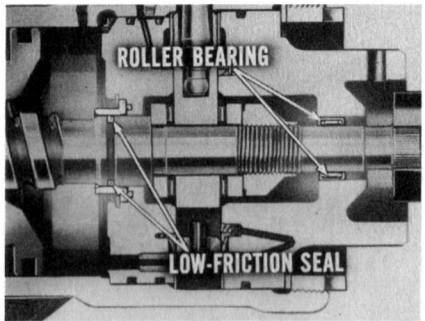

For instance, the shaft journal is fitted with a cast-iron seal ring. It seats in a self-aligning sleeve held in the cylinder head by a snap ring. A seal is located behind the sleeve. That cast-iron seal ring prevents excessive leakage around the wormshaft. Excessive leakage here would result in reduced pressure in the left-turn pressure chamber.

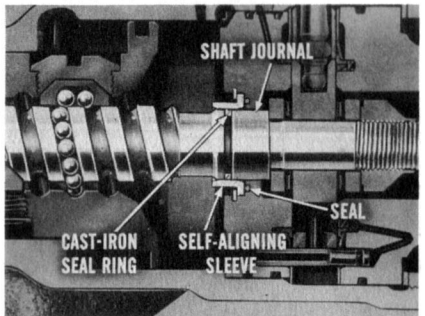

Reaction Area. Now, if you'd cut away the spacer that is sandwiched between the cylinder head and the column support, you'd get a good inside look at the reaction area parts. You'd soon be able to see that the spacer, which is clamped between the cylinder head and column support, *can't* move. The center race, on the other hand, *can* move.

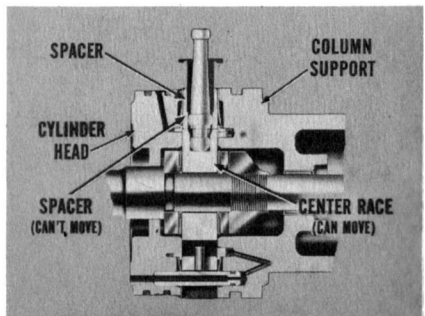

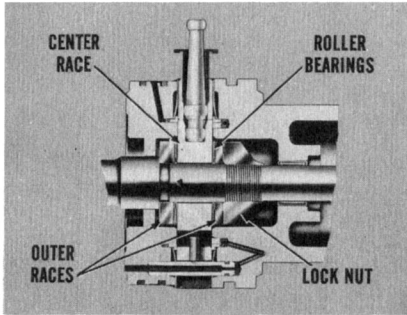

Think of that center race as being a part of a *thrust bearing*. The thrust bearing has two outer races, two sets of roller bearings, the center race and a lock nut holding the entire assembly on the wormshaft.

This thrust bearing design permits a slight end-wise movement of the wormshaft, which means that the center race also moves. Movement of the center race is used to control movement of the steering valve. This action will be explained later. The lower end of the steering valve pivot lever has a spherical bearing surface that rides in, and moves with, the center race.

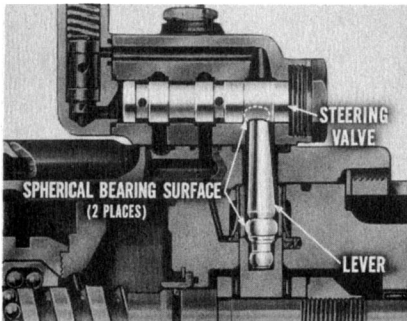

Just above is another spherical bearing surface which pivots in the stationary spacer. Still another spherical bearing surface at the upper end of the lever fits into the steering valve.

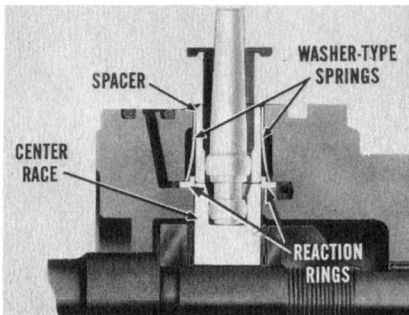

Two reaction rings keep the center race lined up with the spacer. These rings bear against the center race and spacer, and are mechanically loaded by two washer-type springs. Besides that mechanical force, there's *hydraulic pressure* in the picture.

Let's look at how hydraulic fluid flows through the steering control valve body and into the power piston pressure chambers.

HYDRAULIC OPERATION

Neutral Position. When the spool-type steering control valve is in NEUTRAL it straddles the two ports in the valve body, and both ports are partially open. The lower port indexes with a passage which sends fluid under pressure to the *upper* side of the piston. The upper port lines up with a passage supplying pressurized fluid to the *lower* side of the piston. Fluid is directed through both ports equally. This keeps the piston in hydraulic balance.

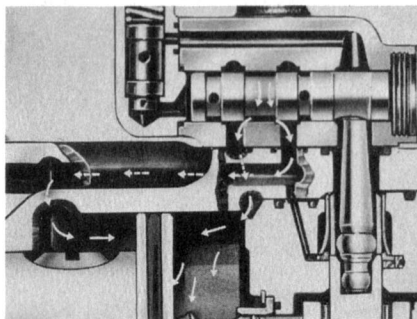

Left Turn. On a *left* turn, the steering valve pivot lever moves the steering valve *down*. This opens the lower port wider and closes the

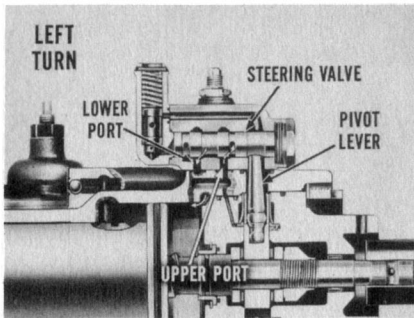

upper port to pressurized fluid coming in around the valve. Fluid through the *lower* port pours into the pump chamber *above* the piston flange. The *upper* port becomes a return flow port to relieve pressure in the chamber *below* the piston flange.

Right Turn. On a *right* turn, the steering valve moves up, opening the upper port wider. The lower port is closed off from the incoming fluid. Pressure increases in the pressure chamber *below* the piston flange, and the lower port becomes a return flow port to relieve pressure *above* the piston flange.

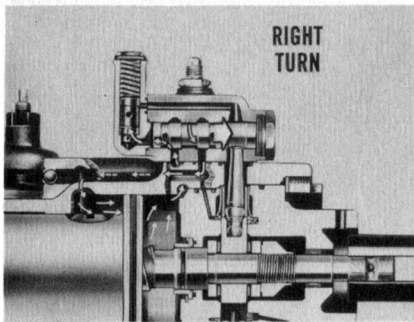

Pressure increases in the pressure chamber *below* the piston flange, and the lower port becomes a return flow port to relieve pressure *above* the piston flange.

You can understand, then, that when the valve is properly adjusted, there will be equal pressure on each side of the piston flange when the valve is neutral.

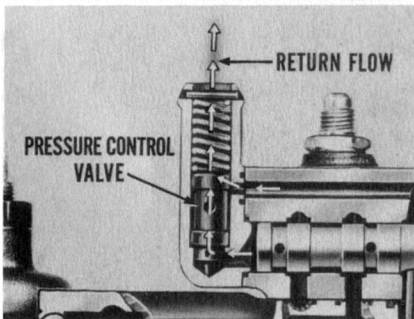

Back-Pressure Control Valve.

The pressure control valve, enclosed in the housing at the end of the control valve body, is also a spool-type valve. Its job is to maintain pressure by metering return flow to the reservoir. In other words, it acts more like a back-pressure regulator valve.

Reaction Area. As mentioned previously, lateral movement of the center race is used to control movement of the steering valve. Here's how that reaction is brought about.

Left Turn. When the steering wheel is turned to the left, the sector shaft tends to hold the piston stationary. Because of this momentary resistance, the worm tries to thread its way out of the piston. This tends to move the wormshaft upward.

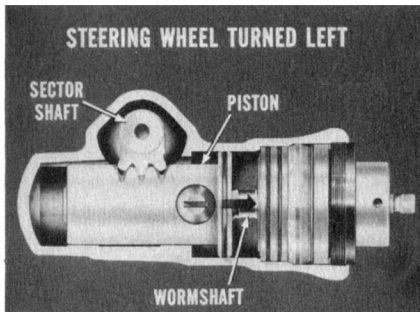

That wormshaft movement, in turn, moves the center race which carries the lower end of the pivot lever with it. So, the upper end of the lever moves the steering valve. This opens the left-turn port wider, and closes the right-turn to pump pressure. Fluid enters the left-turn pressure chamber, forcing the piston downward for a left turn.

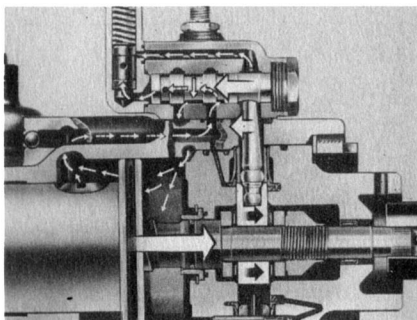

A sleeve, pressed into the cylinder head, provides a passage from the left-turn pressure chamber to the reaction area above the center race. This is how pressurized fluid is directed against the upper reaction seal. The reaction seal, in turn, presses against the reaction ring and the compensating washer. As you can

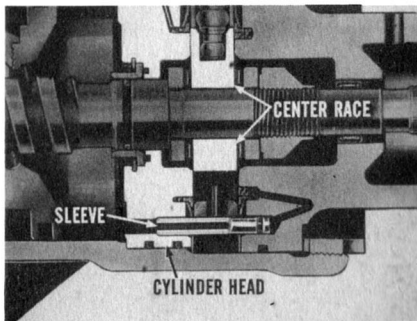

see, there is spring pressure, plus hydraulic pressure, resisting movement of the center race. It is this resistance that provides the “feel-of-the-road” characteristic.

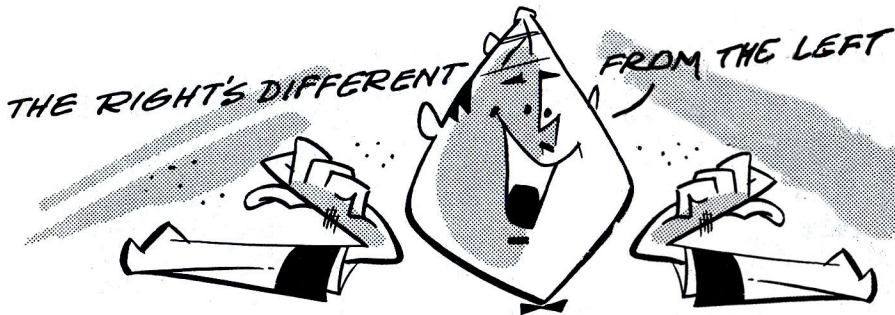

Right Turn. Operation within the reaction area during a right turn is

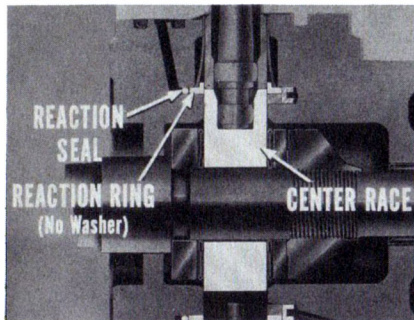

slightly different than with a left turn. On the lower side of the center race, for instance, there's a reaction seal and ring – but there's no compensation washer. As a result, there is more hydraulic pressure to resist center race movement on a left turn than there is on a right turn.

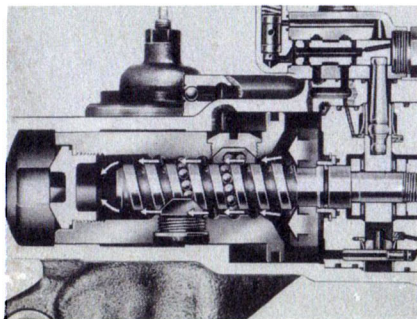

Here is why there is more hydraulic resistance on a left turn. The pump chamber above the piston flange is pressurized on a left turn. Fluid under pressure also flows between the wormshaft and piston flange and fills the chamber of the piston end of the the wormshaft.

So, fluid in that area pushes *up* on the end of the worm, while fluid in the left-turn pressure chamber pushes *down* on the piston. Hydraulic pressure on the compensating washer, however, *offsets* the pressure on the end of the wormshaft. So the driver feels the *same* resistance to turning in *each* direction.



Here's something else. Keep in mind that as soon as the driver lets up on steering wheel pressure, the pivot lever returns the steering valve to Neutral position. You see, there is no longer any mechanical force trying to move the center race, so the reaction springs, along with hydraulic pressure on the reaction rings, move the center race and pivot lever — and therefore, the valve — into Neutral. Hydraulic pressure again becomes equal on each side of the piston.

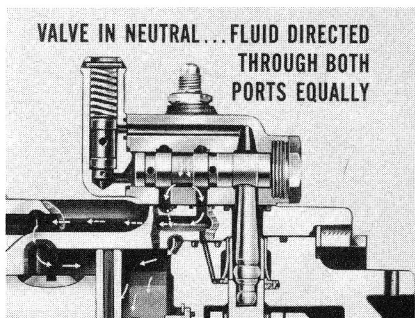

You can understand, therefore, that the gear won't resist return of the front wheels to straight-ahead position after they have completed a turn. Just as it's true in a manual steering set-up, so is it true in a power steering set-up: *front end geometry* is responsible for straightening the front wheels after a turn.

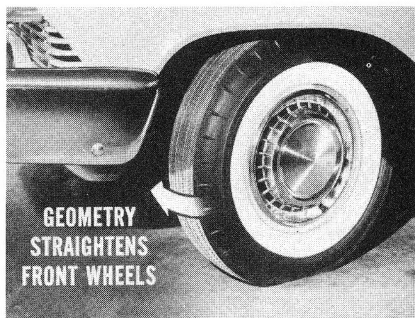

Gear Resists Road Shock. One good point in favor of power steering is that it's got a lot of built-in safety features. For example, if the wheel hits a chuckhole, or if a tire blows out, the shock of the wheel trying to change direction will be transmitted to the wormshaft.

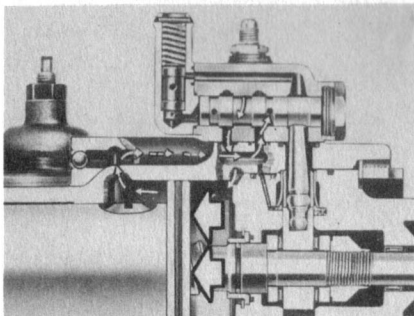

That movement, in turn, moves the steering valve. Pressure immediately goes to one side of the piston to prevent the front wheel from changing course. In support, power quickly comes to the rescue whenever there's a case of severe front wheel shock.

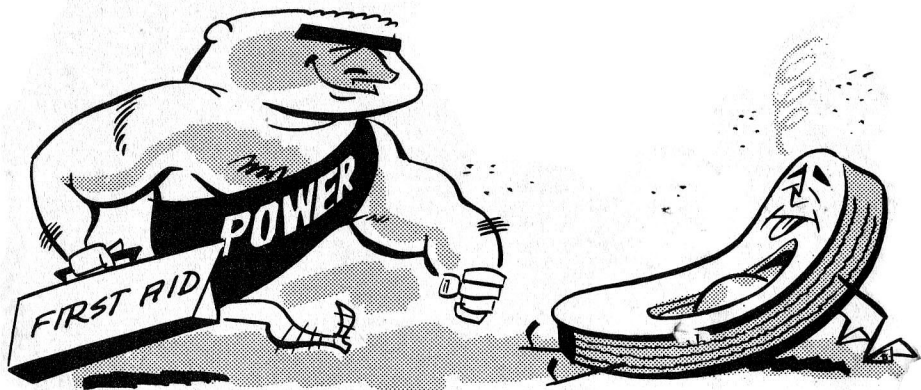

MAINTENANCE

As you know, the power gear won't work right unless the pump delivers enough pressure. So, as a starter, always check fluid level. Then, check the drive belt adjustment. If belt tension and fluid level are okay, and there's a lack of assist in both directions, see if the pump is at fault.

Test Pump Pressure. Anytime you suspect the pump as being the cause of a condition reported by an owner, make a pressure test. Install a 1500-psi gauge in the pressure line between the pump and gear. Make sure the gauge valve is open so oil flow to the gear won't be restricted. Also, connect a tachometer to the engine.

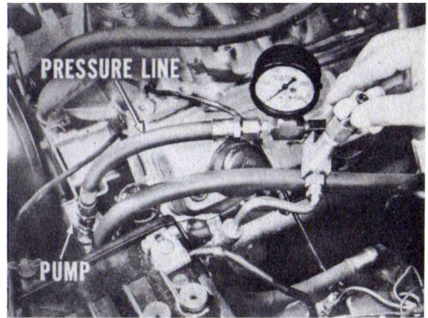

Start the engine and let it run until both it and the power steering fluid are at normal operating temperature. Fluid temperature should be about 175° F. Set engine idle at 475 to 500 r.p.m.

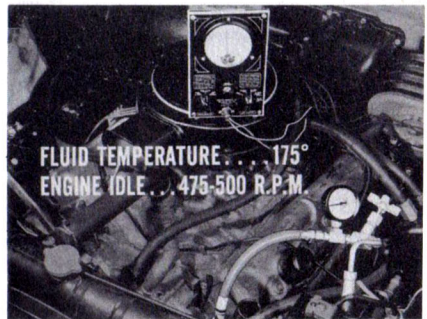

Now, gradually close the gauge valve. Pressure should rise to between 800 and 950 psi. Open the valve after making this test. If pressure is less than 800 psi, pump output is too low, and the trouble isn't in the gear. It's either in the flow valve, relief valve, or there's internal leakage in the pump.

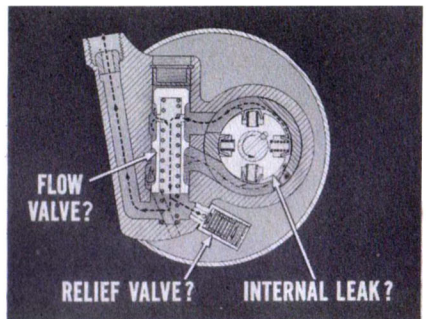

If your test shows *almost no pressure*, you'll have to repair or replace the pump, depending on the type of pump.

NOTE: On power units with the sleeve- or rotor-type pumps, follow the service suggestions with which you are already familiar. Only the current production, slipper-type pump will be covered in this reference.

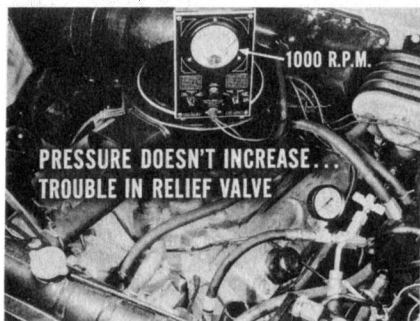

If your tests show that pressure is only slightly below standard, make this further test. Close the gauge valve and increase engine speed to about 1000 r.p.m. If the pump pressure doesn't increase noticeably, the trouble is in the relief valve.

Now, even if pump pressure registers over 800 psi, that doesn't necessarily give the pump a clean bill of health. While your test may show pressure is acceptable in the service department, the pump may not deliver enough volume at low speed when you take the car out on the road and put it under load.

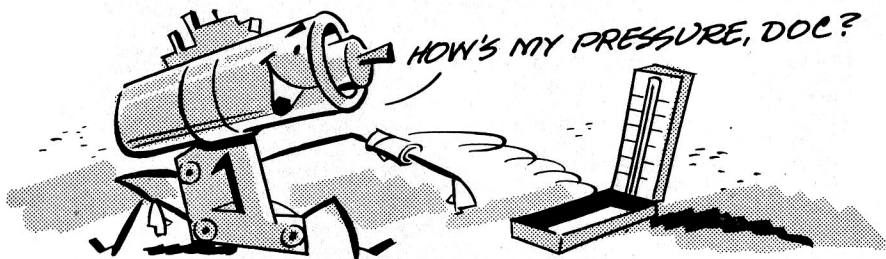

Remember—when making a diagnosis to determine whether the pump or the gear is at fault, it's easier to install another pump for testing purposes than to pull the gear out of the car and disassemble it. So, take a pump you know is good, install it, and road-test the car. If the steering is okay, then you'll know the original pump is at fault, and it will have to be repaired or replaced. On the other hand, if

changing the pump doesn't correct the condition, and external adjustments to the gear itself had no effect, you'll know the gear must come out because of some internal condition that needs correcting.

SLIPPER-TYPE PUMP SERVICE

Relief Valve Replacement. Let's suppose your pressure test shows that the pump relief valve isn't working. In order to replace the valve you'll have to remove the pump. So, remove the pump, and drain it. Then, remove the reservoir and pump mounting brackets. Reinstall the pump front bracket for use as a holding fixture.

NOTE: Use spacer washers between the pump body and bracket to keep the bolts from bottoming in the housing.

Finally, remove the pressure relief valve. Throw away the old gasket. Install a new gasket and the new relief valve assembly.

Pulley Removal. If you have occasion to replace the original pump you'll have to remove the pulley, and install it on the replacement pump. Or, if there is a leak at the pump drive shaft oil seal you'll have to remove the pulley to replace the seal. To remove the pulley properly, clamp the front mounting bracket in a vise. Next, install the Puller, Tool C-3615, and remove the pulley.

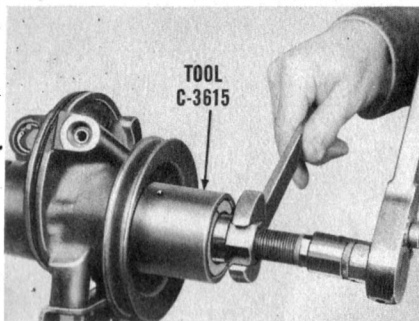

NOTE: When you assemble the puller to the pulley hub, see that the tapered ends of the two half collars fully engage the hub before you turn the puller screw.

Pulley Installation. For pulley installation you'll need a heavy-duty arbor press and a Supporting Tool C-3643. You see, total pressure exerted by the press must be applied only to the shaft, or the pump body and rotor will be damaged. So, put the pump and pulley in the press, with the pump body supported by the special tool.

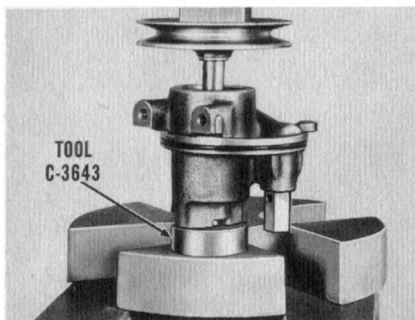

Press the pulley on the shaft until the hub is flush with the end of the shaft.

Pump Drive Shaft Oil Seal Removal. If there is an oil leak at the pulley end of the pump drive shaft, replace the oil seal.

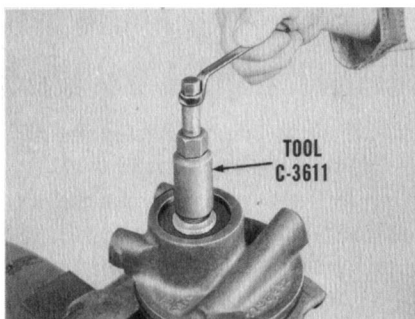

Remove the Pulley. Use the Puller, Tool C-3611 which threads into the seal. Turn the puller screw to pull the seal from the pump body.

Pump Drive Shaft Oil Seal Installation. When installing a new drive shaft oil seal, support the pump evenly on a vise. Then, install the seal with its lip toward the housing, and use the Seal Driver, Tool C-3640, to drive the seal firmly into place.

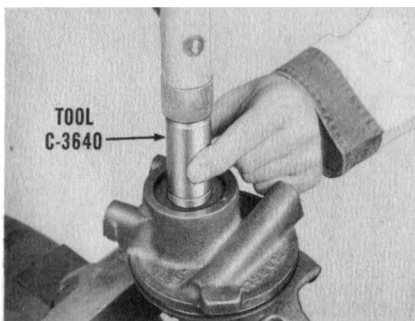

STEERING GEAR SERVICE

Sector Shaft Oil Seal Replacement. This seal, at the lower end of the sector shaft, can be replaced while the gear assembly is in the car.

To remove the seal, disconnect the drag link from the steering arm. Use Puller, Tool C-3646 to remove the steering arm from the end of the sector shaft. Then, with snap ring pliers, remove the snap ring and seal retainer from the lower end of the gear housing.



To pull the old seal from the housing, use the Seal Puller, Tool C-3350 and Adapter, Tool SP-3056.

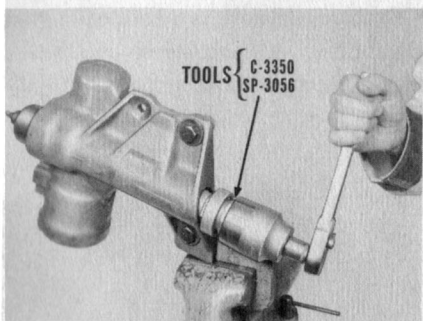

Install the new seal with its lip toward the roller bearings in the housing. Start the seal into the housing. Then, place the Adapter SP-3052 over the end of the cross shaft. Next, thread the Seal Puller C-3350 onto the end of the sector shaft and tighten it until the seal is fully seated. Reinstall the retainer, snap ring and steering arm. Finally, reconnect the drag link.

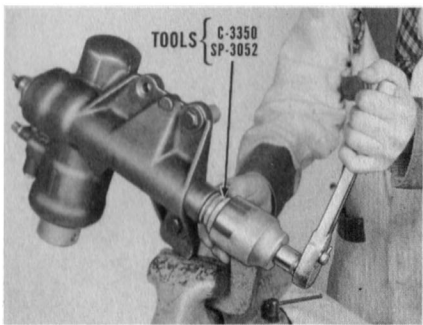

Steering Valve. You can service the steering valve while the unit's on the car. Disconnect the two hoses from the valve. Cap the ends to

keep out dirt, and tie the hoses so they're out of the way. Keeping the hose ends high will keep the reservoir from being drained.

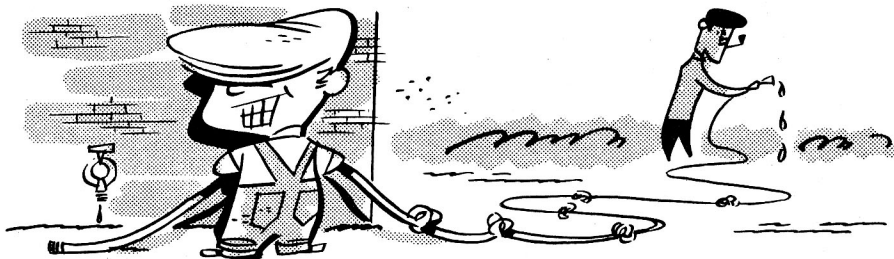

Next, remove the two steering valve body attaching screws and lift the body from the housing. Discard the three "O" rings, as you'll be using new rings in reassembly. If you wish to remove the steering control valve so you can clean and inspect it, remove it from the pressure control valve end of the body so you don't have to remove the body end plug. Just unscrew the two pressure control valve housing screws, and separate the body and housing. The steering valve will slide easily out of the body, so don't drop it or the valve lands might get nicked.

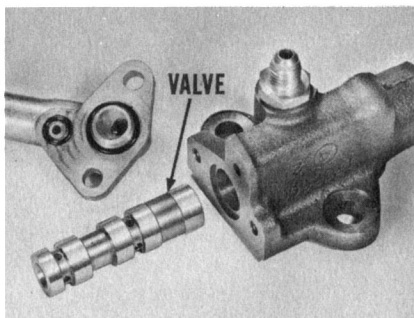

pressure control valve end of the body so you don't have to remove the body end plug. Just unscrew the two pressure control valve housing screws, and separate the body and housing. The steering valve will slide easily out of the body, so don't drop it or the valve lands might get nicked.

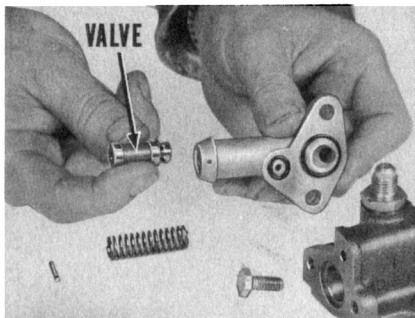

Pressure Control Valve. To remove the pressure control valve for cleaning and inspection, push the retaining pin from the housing. The spring and valve will slide out. If the valve doesn't slide out freely, check for burrs on the inside of the housing bore where the retaining pin enters. If you find any burrs, remove them

first, to avoid damage to the valve. You can polish out any minor nicks or burrs on the steering or control valves with crocus cloth. Be careful not to round off the sharp edges of the lands. Use new "O" rings and reassemble the pressure control valve housing to the steering valve body. Tighten attaching screws to 10 foot-pounds.

When installing the steering control valve body, tighten the screws to 15 foot-pounds.

Removing Gear From Car. It's easier to take the gear assembly out through the passenger compartment whenever removal is necessary. It *can* be removed through the engine compartment on some models, but master cylinder brake lines will interfere. That would call for removing the lines, and then bleeding the brakes after reinstalling the gear.

Here's another good reason for taking the gear out through the passenger compartment. You can disconnect the drag link but leave the steering gear arm attached until you get the assembly on the bench. Also, after you remove the steering wheel and column jacket you do not have to disconnect the steering tube from the wormshaft. This makes it easier to handle the gear as you remove and install it through the floor pan. Disconnecting and connecting the steering tube at the coupling is a lot easier when it is done at the bench.

ADJUSTMENTS

Hard Steering—Lack of Assist (Both Directions). Hard steering, or a lack of assist in both directions, could be caused by oil leakage from the left-turn to the right-turn pressure chamber. In a case like this, inspect the "D" ring on the piston flange first. If it's damaged, replace it.

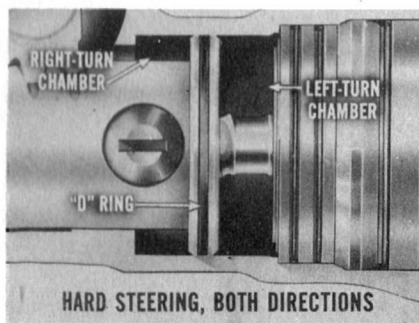

Poor Returnability. If a car has poor returnability in *both* directions, chances are it is caused by either incorrect front end alignment, low

tire pressure or a bind in the steering linkage. But if returnability is poor in only *one* direction, road-test the car for evidence of “self-steering”. When you find this combination of conditions, a steering valve adjustment is necessary. Let’s say your road test showed poor returnability from a right turn, or self-steering to the right.

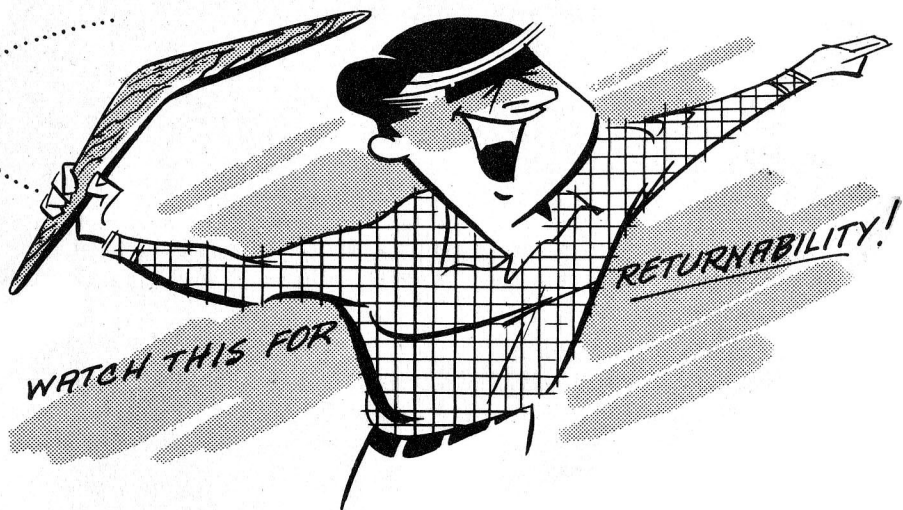

If so, adjust the valve body mounting screws to 7 ft.-lbs. That’s just enough tension to permit moving the valve body a slight amount, and have it stay where you put it.



With a hammer, tap *lightly* on the plug at the upper end of the valve body to move it downward. Then, take your hammer and torque wrench along, and road-test the car.

You may have moved the valve body too far. In this case, you'd have self-steering to the left, and probably poor returnability from a left turn. So, the valve body would have to be tapped lightly *upward*. To move it up, you tap on the back-pressure valve housing mounting screws. Be very careful not to hit the housing. Clearances inside are critical, and a small dent in the housing would interfere with back-pressure valve operation.

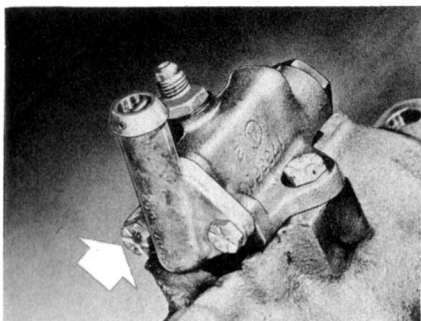

When you adjust the steering valve properly, returnability will be the same in both directions. Then, tighten the body attaching screws to 15 ft.-lbs., and you're done.

Backlash Adjustment. This adjustment can be made while the unit's in the car. Loosen the adjusting screw lock nut and turn the sector shaft adjusting screw out until you feel some backlash. Then, turn the adjusting screw *in* until backlash barely disappears. Turn the adjusting screw *in* $\frac{3}{8}$ - to $\frac{1}{2}$ -turn more, to provide proper preload on the sector teeth. Finally, tighten the adjusting screw lock nut to 50 ft.-lbs.

SUMMARY

You now have the story on the Constant-Control, Full-Time power steering unit. It represents a completely new advance toward providing the finest in power steering. As a result, it probably will become one of the most popular items on our 1958 models. The more you know about it, and how to keep it in shape to operate to the owner's satisfaction, the farther you'll go in holding service customers.

**RECORD YOUR ANSWERS
TO THESE QUESTIONS
ON QUESTIONNAIRE NO. 120**

All adjustments to the Constant-Control power steering are made externally, without having to remove or disassemble anything.

RIGHT

1
WRONG

The wormshaft and piston are serviced only as an assembly.

RIGHT

2
WRONG

When it's in Neutral position, the spool-type steering valve straddles two ports in the valve body which keeps the piston in hydraulic balance

RIGHT

3
WRONG

When the steering valve is properly centered in the neutral position, there's equal pressure on each side of the piston flange.

RIGHT

4
WRONG

Spring pressure plus hydraulic pressure resists movement of the center race and provides a "feel-of-the-road" characteristic.

RIGHT

5
WRONG

There's more hydraulic force trying to resist center race movement on a left turn than there is on a right turn.

RIGHT

6
WRONG

Constant-Control power steering doesn't resist return of the front wheels to straight-ahead position by the front end geometry.

RIGHT

7
WRONG

In case of severe front wheel shock, wormshaft movement moves the steering valve and pressure immediately goes to one side of the piston to keep front wheels from changing course.

RIGHT

8
WRONG

Poor returnability in both directions points to incorrect front end alignment, low tire pressure, or a bind in the steering linkage.

RIGHT

9
WRONG

Once the steering valve body is adjusted properly for equal assist in both directions, tighten the attaching screws to 15 ft.-lbs.

RIGHT

10
WRONG