

SERVICE REFERENCE BOOK
of the MASTER TECHNICIANS SERVICE CONFERENCE

session no.

129

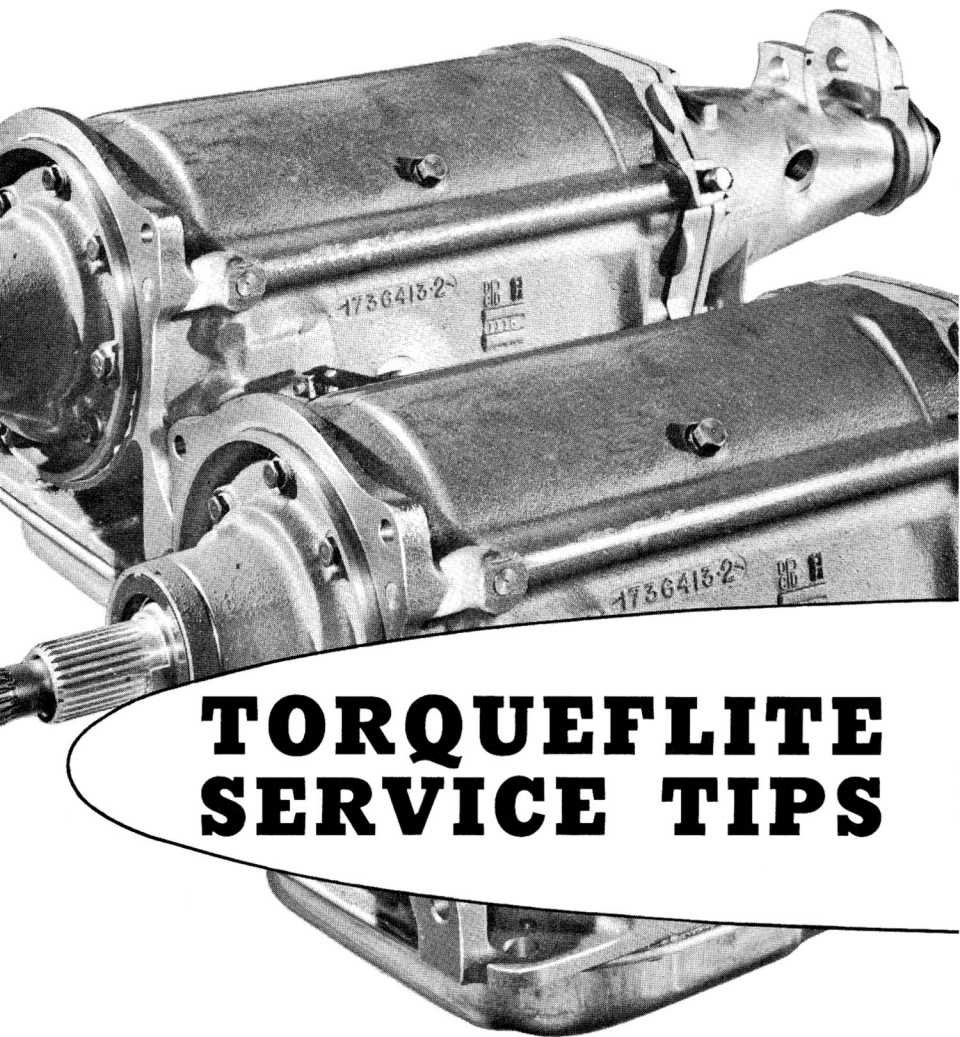

TORQUEFLITE
SERVICE TIPS

PREPARED BY CHRYSLER CORPORATION
Plymouth • Dodge • De Soto • Chrysler • Imperial

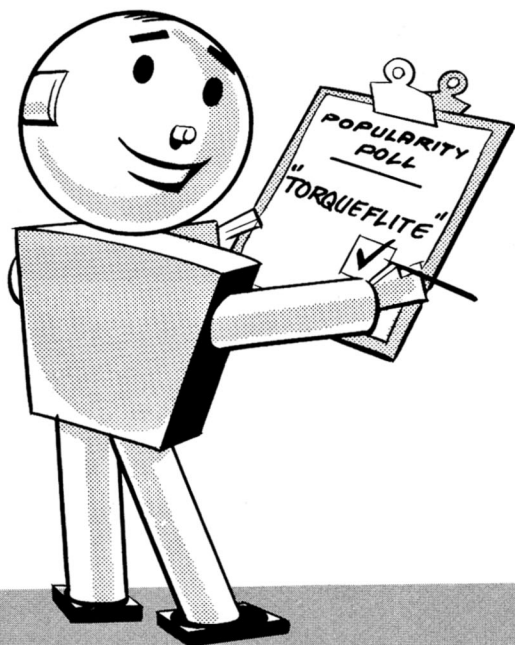

TORQUEFLITE TRANSMISSIONS ARE TOPS IN POPULARITY!

Ever since TorqueFlite made its bow in 1956, its popularity has been on the rise. More than 54% of all 1958 Chrysler-made cars produced to date have been equipped with TorqueFlite—and that percentage keeps growing every day.

When a transmission becomes so popular, the need for knowing how to provide the service it may require becomes greater. This reference book, therefore, presents a new approach to TorqueFlite diagnosis and maintenance designed to help you keep the unit operating at its best. Basic adjustments are covered, along with new diagnosis tips that you'll find useful in your TorqueFlite work.

Here's where to look for the TorqueFlite information you need:

	<i>Page No.</i>
BASIC TORQUEFLITE OPERATION	4
FLUID LEVEL CHECK	5
CHECK LEVEL PROPERLY	5
WHEN TO CHANGE FLUID	6
EXTREME COLD OPERATION	6
ANTIFREEZE IN TRANSMISSION FLUID	7
FLUSH THE CONVERTER	7
THROTTLE LINKAGE ADJUSTMENT	8
CHECK LINKAGE ADJUSTMENT	9
ADJUST THROTTLE LINKAGE	10
PUSH-BUTTON CABLE ADJUSTMENT	11
DIAGNOSIS	14
FRONT CLUTCH TEST	16
KICKDOWN BAND TEST	16
KICKDOWN BAND ADJUSTMENT TIPS	18
REAR CLUTCH SLIPPAGE	18
LOW AND REVERSE BAND	19
HYDRAULIC PRESSURE TESTS	19
LINE PRESSURE	20
GOVERNOR PRESSURE	21
LUBRICATION PRESSURE	22
COMPENSATED THROTTLE PRESSURE	22
REAR CLUTCH PRESSURE	23
ROAD-TEST FOR OVER-ALL PERFORMANCE	24
NEUTRAL	24
NEUTRAL TO DRIVE—NEUTRAL TO REVERSE	24
SHIFT QUALITY	25
DRIVE	25
3-2 AND 3-1 KICKDOWNS	25
CLOSED THROTTLE 3-1 DOWNSHIFT	25
BUTTON-SELECTED SHIFT TESTS	26
REVERSE	26
FILLER TUBE FLUID BLOWOUTS	26
SUMMARY	27

BASIC TORQUEFLITE OPERATION

When you think about how the TorqueFlite transmission works *basically*, you quickly realize that disassembly is quite often unnecessary. In fact, the best way to save time and effort is to regard disassembly as a last resort. Most TorqueFlite malfunctions can be corrected merely by making external adjustments.

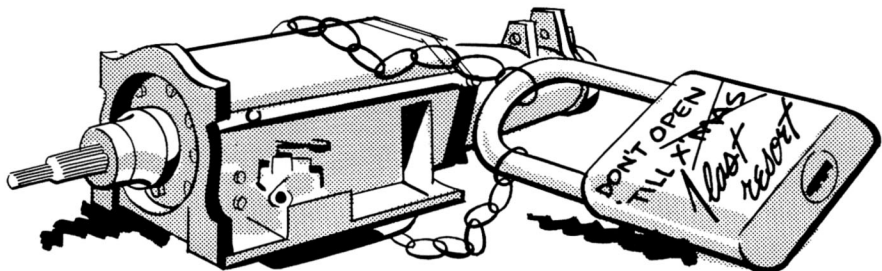

It will help to simplify your diagnosis of the cause of improper operation if you remember that the unit is basically a mechanical gearbox. Engine power is routed through planetary gear sets to provide torque multiplication for first gear, second gear, and reverse.

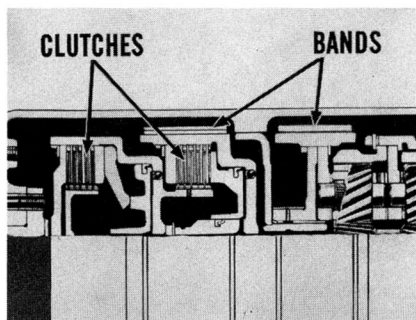

Inside the transmission, the flow of power is controlled by two multiple-disc clutches and two bands. When these clutches and bands do what they're designed to do, the transmission works beautifully. But if a band happens to slip—or grab—or if a clutch slips—operation won't be normal.

If, early in your diagnosis procedure, you are able to isolate the malfunction to the one band or clutch that isn't operating properly, you will greatly simplify the job of locating the specific cause. Before you can pin the trouble to a specific band or clutch, however,

there are certain tests you must make. To be specific, you must be sure that fluid level is correct, and that throttle linkage and push-button cable adjustments are correct.

FLUID LEVEL CHECK

Checking fluid level, of course, should be your first step before you make any other tests or adjustments. Clutches and bands, after all, are applied by hydraulic pressure. Unless fluid level and fluid pressures are up to specifications, the clutches and bands can't work properly.

If the fluid level is incorrect, it can cause erratic shifting. If the level is too *low* it can even lead to clutch failure. *Too much* fluid in the unit will result in "foaming". This will lead to loss of pressure, and will also cause erratic shifting.

Check Level Properly. There's more to checking fluid level than pulling out the dipstick. First, you should check the level with the engine running at normal idle speed. So, set the hand brake, and let the engine idle. Next, operate all five push buttons slowly, returning to the Neutral button each time. This gets all the passages filled to operating capacity. After that, you're ready to check the level.

NOTE: Keep a sharp eye out for a dipstick cap that might have been pushed up above the stake point. That can let the dipstick go too deep, and give you a false reading.

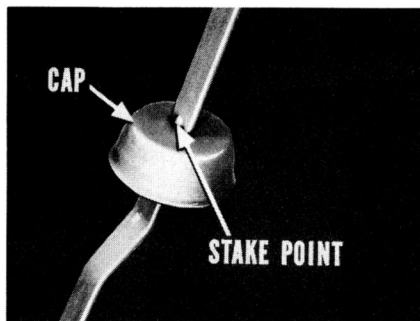

If you're checking level on a car that's been parked for a fairly long time and the fluid feels cool, the level should be at the LOW mark—plus or minus $\frac{1}{4}$ ". But if the car's been driven about 8 to 10 miles and the fluid is thoroughly warmed up, the level should be at the FULL mark—or $\frac{1}{2}$ " below.

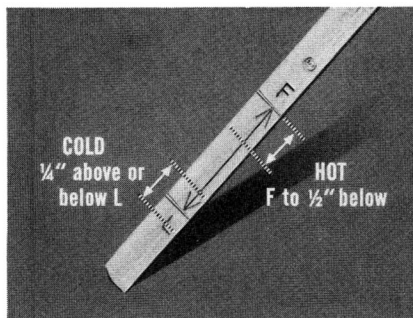

If the car's been driven over a long distance at high speeds, and the level is checked as soon as the car stops, the level might rise to about $\frac{1}{4}$ " above the FULL mark.

NOTE: Only automatic transmission fluid, type "A", should be used. Adding special compounds which claim improved performance, sludge elimination, or reduced leakage is *not recommended*.

When To Change Fluid. On cars used for police, taxicab, trailer towing, heavy traffic service—or continuous operation at above-normal loads—drain and refill the transmission every 10,000 miles. This also applies to trucks engaged in severe service. Under normal operating conditions, change the fluid at 20,000-mile intervals.

Extreme Cold Operation. If the engine of a car equipped with the TorqueFlite transmission is hard to start when average temperatures are consistently below -10° F., replace one quart of transmission fluid with *refined kerosene*. Do this *only once* during the low temperature season. Subsequent additions to maintain fluid level should be of Automatic Transmission Fluid, Type A.

NOTE: Always make sure the dipstick cap seats properly over the filler tube to keep dirt out of the transmission.

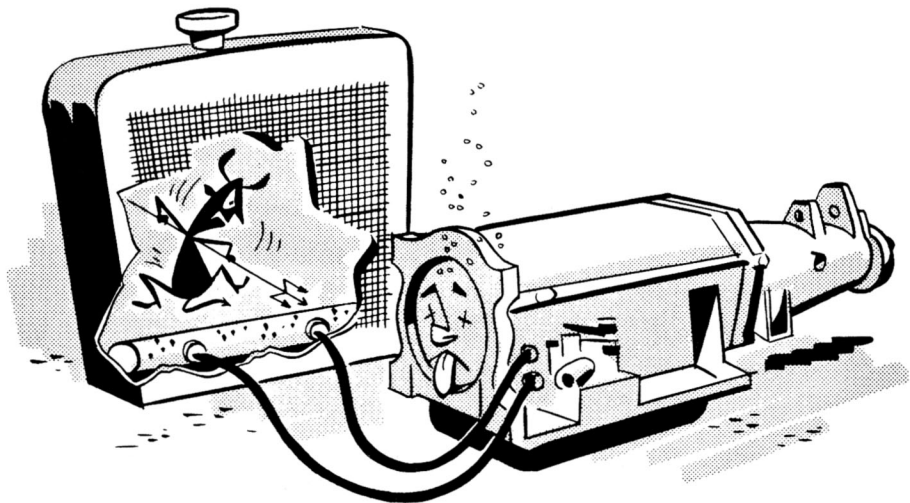

Antifreeze in Transmission Fluid. If you find antifreeze in the transmission fluid, check for a leak in the cooler at the bottom radiator tank. Disconnect the cooler lines and use air pressure (no more than 50 pounds) to test for cooler leaks. If you find a leak, remove the cooler for repair.

If antifreeze should get into the transmission, it will cause damage. The torque converter will have to be drained and flushed to remove contamination and any fine metal particles trapped inside. The entire transmission will have to be disassembled, valve body and all, so parts can be cleaned and inspected. Be sure to check for rust behind the front pump. If the clutch disc friction material is soft, replace the discs.

Flush the Converter. Make sure the drain plug is in place. With a screwdriver, reach into the converter and turn the large splined stator hub counterclockwise until a rectangular slot can be seen at the top of the hub. Use a long-spout can to pour two quarts of clean kerosene into the hub. Close the hub opening with masking tape. Remove the ignition coil wire so the engine won't start. Then, crank the engine for about 10 seconds to wash out the converter.

Remove the masking tape and plug so the kerosene will drain out. Repeat the flushing operation until the drained kerosene is perfectly clear. Rotate the converter with the drain plug removed to wash out last traces of kerosene. Finally, reinstall the drain plug.

THROTTLE LINKAGE ADJUSTMENT

Many cases of harsh shifting and clutch slippage during acceleration can be traced to an incorrect throttle linkage adjustment.

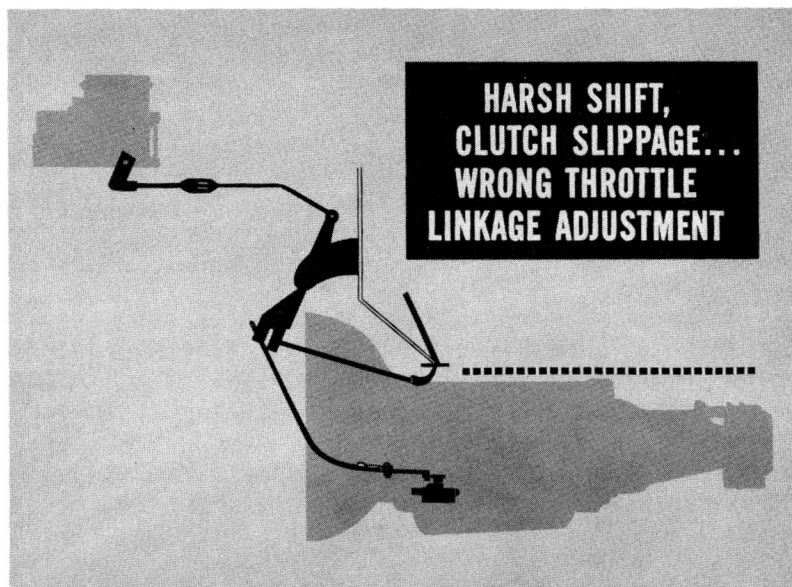

The amount of engine torque transmitted through the converter and into the transmission is directly related to throttle opening. The throttle linkage acts on the throttle valve in the transmission valve body, so that throttle pressure increases in proportion to engine torque. So, shift *timing* and shift *quality* are affected by throttle opening.

If throttle linkage is adjusted so that throttle pressure gets *too high* in relation to engine torque, there will be rough, harsh shifting.

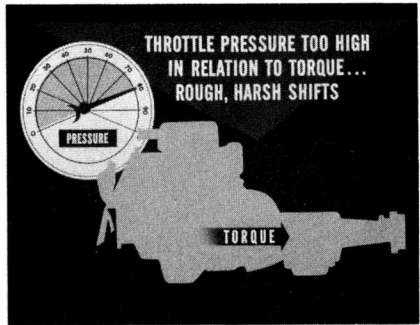

On the other hand, if the linkage is adjusted so that pressure is *too low* in relation to engine torque, "apply pressure" acting on the bands and clutches will be too low. They'll slip, and the engine will race when the transmission shifts.

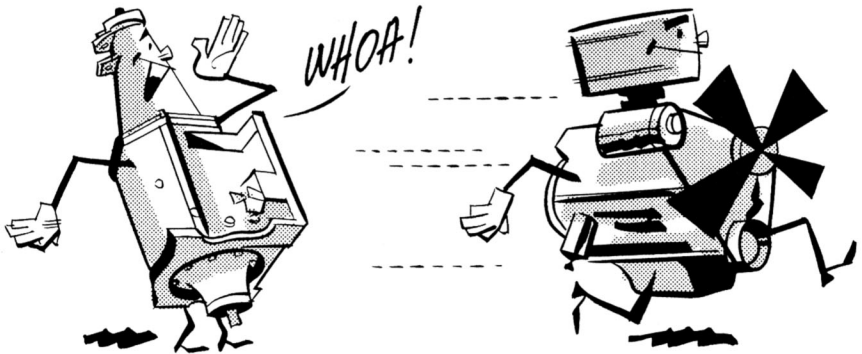
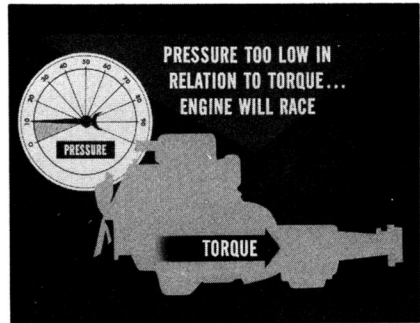

Check Linkage Adjustment. Before checking the linkage setting, make sure that carburetor adjustments and idle speed are okay. Incorrect engine idle speed, or poor engine performance can result

in the same type of shift problems as you get from incorrect throttle linkage adjustment. So, the engine should be checked first.

The carburetor throttle lever must be in idle position—off the fast idle cam. Disconnect the throttle rod from the throttle lever at the carburetor.

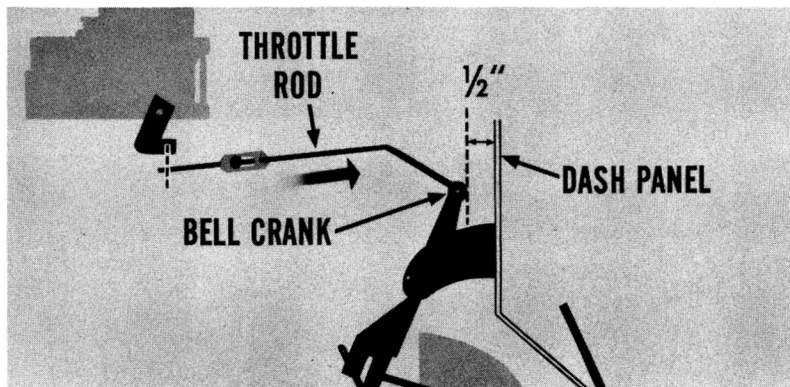

Next, move the throttle rod rearward to the limit of its travel. There should be $\frac{1}{2}$ -inch clearance between the rear edge of the bell crank and the dash panel. With the bell crank in that position, the end of the throttle rod should line up with the carburetor throttle lever without moving the lever from idle position.

Adjust Throttle Linkage. If the throttle rod cannot be connected to the carburetor throttle lever without moving the lever or changing the $\frac{1}{2}$ -inch clearance, you'll have to adjust its length. While you're at it, see that the bell crank lever is tight on its shaft. You won't get a good throttle linkage adjustment if there's any lost motion present.

If you don't have $\frac{1}{2}$ -inch clearance between the bell crank and the dash panel, leave the throttle rod disconnected at the carburetor. Make sure the engine is warmed up, and the carburetor adjusted to give recommended idle speed. Loosen the throttle lever locknut at the transmission. Have a helper hold the bell crank lever so that the $\frac{1}{2}$ -inch dimension is correct. With the bell crank lever held, pull the

transmission end of the bell-crank-to-throttle-lever linkage as far forward as you can, and tighten the locknut to secure the adjustment.

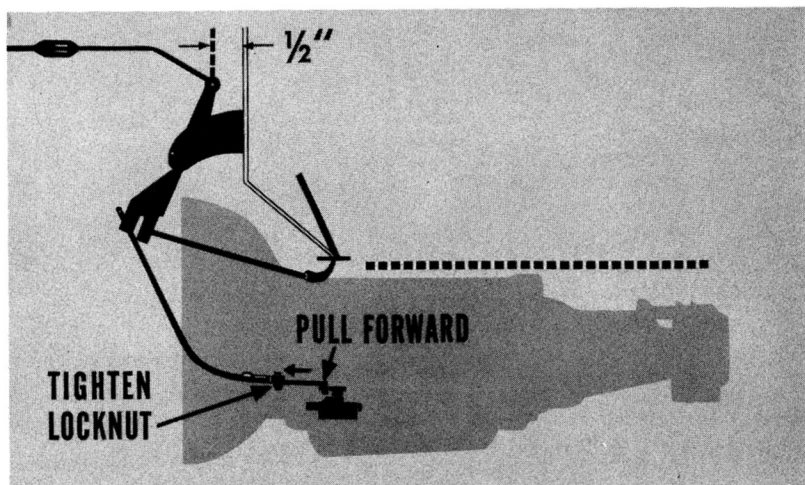

Then, with the bell-crank-lever-to-dash-panel clearance correct, adjust the length of the throttle rod so it can be connected to the carburetor throttle lever without moving the lever.

Incidentally, don't forget to check the accelerator pedal position. You must be able to get a kickdown without compressing the floor-mat. If necessary, you can adjust the length of the pedal-to-bell-crank rod to increase or decrease pedal travel.

PUSH-BUTTON CABLE ADJUSTMENT

Once the throttle linkage adjustment is correct, you can check the push-button cable adjustment. If this is wrong, it can cause poor shift performance, engine runaway, and clutch slippage. That's because regulated line pressure is directed through the manual valve to the control valves. From the control valves, line pressure goes to the band servos, and to the clutch-apply pistons.

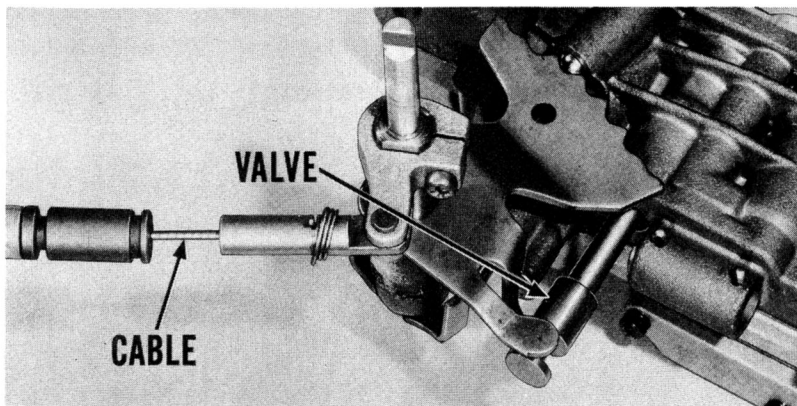

The manual valve, remember, is positioned by the push-button cable. So if the manual valve is improperly positioned, flow of fluid through the valve will be reduced. In short, when the flow to the apply pistons is reduced, the transmission won't perform as it should. That's why the cable adjustment must be checked before even thinking about disassembly of the unit.

You'll need a little help to adjust the cable. So have somebody hold the "R" button *all the way in*

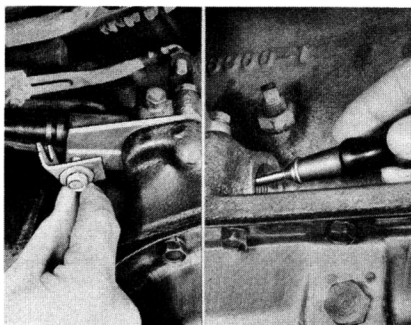

to remove free-play at the button box. Next, loosen the screw holding the cable adjustable bracket to the adapter housing. Remove the neutral starter switch. Use a screwdriver to hold the manual valve lever in *reverse detent position*.

Push the cable *all the way* into the adapter housing, and mark it. Do not use excessive force. Pull it *out all the way*, and mark that point on the cable. Then, put a mark midway between these two marks. Push the cable *in* until this mid-mark is flush with the adapter housing, and tighten the screw.

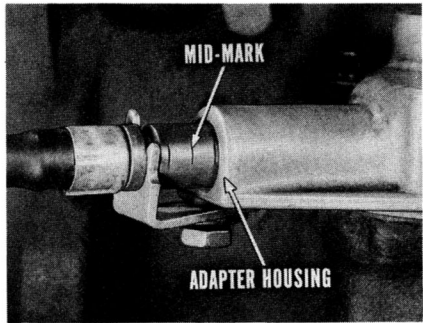

Reinstall the neutral starter switch. Be sure the neutral starter switch lever is centered in the hole so it can make positive contact with the switch. If the lever is not centered, remove the oil pan and correct the condition before installing the switch.

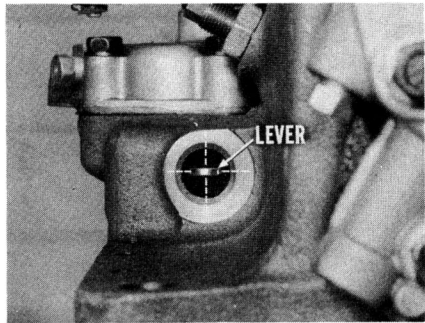

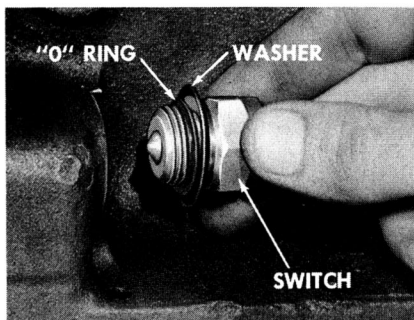

Next, clean the switch contact surface on the transmission so the switch will have a good ground. Install the mounting washer with the concave surface *away from* the switch. Place the rubber "O" ring next to the washer, and install the switch in the case.

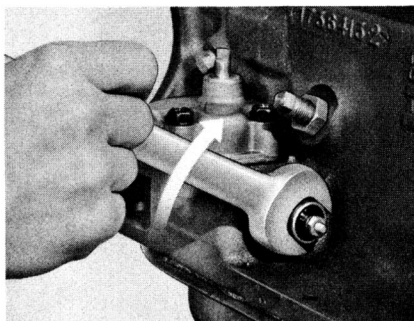

Turn the switch in until the washer contacts the case. Then, tighten the switch an extra $\frac{1}{3}$ - to $\frac{1}{2}$ -turn. Turning it in any farther will affect the cable adjustment. Finally, connect the wire and check neutral switch operation.

DIAGNOSIS

When it comes to TorqueFlite diagnosis, a case of *failure to work* is usually easy to figure out. As an example, if there are no shifts at



all, chances are the throttle or the governor valve is stuck. When these valves stick, pressure can't get to the servos and pistons to actuate them.

But when you get a very *general* report that the customer "doesn't like how the unit shifts", you may be in for a busy time. Many things in the hydraulic system can affect the *quality of shift*. But remember, improper operation of a band or clutch is always the basic cause of poor shift quality. If a band *grabs*, the shift is *harsh*. If a band or clutch *slips*, there'll be an engine *runaway* condition.

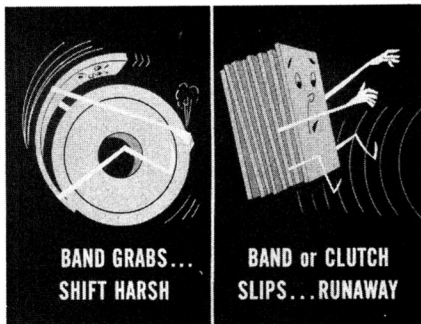

Knowing what the bands and clutches are doing is the key to TorqueFlite diagnosis. A few simple tests can tell you whether the bands and clutches are right. Knowing that, your job is simply one of testing and correcting the things affecting the operation of a specific band or clutch.

So after checking fluid level, and making throttle linkage and push-button cable adjustments, make sure that engine performance is okay. Poor engine operation can affect shift quality, too. If engine performance is good, warm up the engine and transmission and road-test for front clutch slippage.

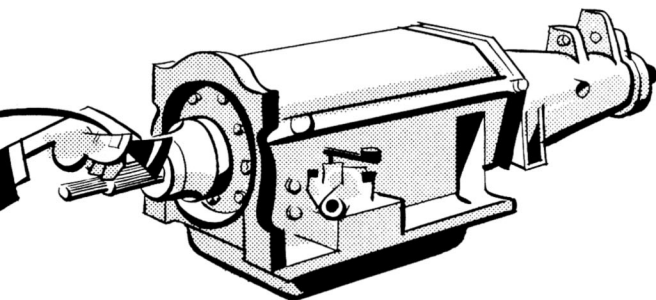

Front Clutch Test. With the engine idling, and the car standing still, engage the “D” button. The front clutch will engage. The rear clutch as well as both bands will be released. The transmission is in low gear or “breakaway” and any slippage experienced will be in the front clutch.

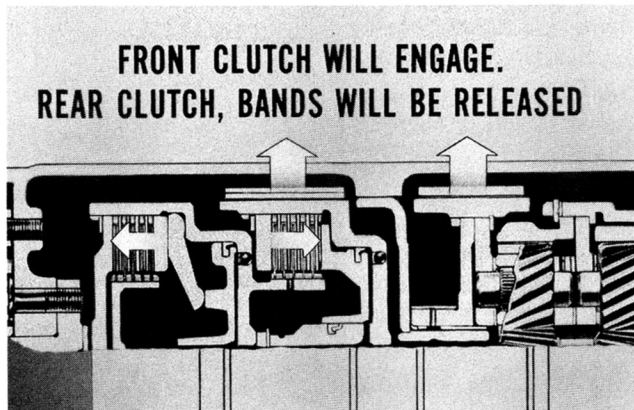

Now, accelerate with $\frac{3}{4}$ -throttle. If car speed responds quickly, without engine runaway, you'll know the front clutch is okay.

If car speed doesn't respond quickly with $\frac{3}{4}$ -throttle acceleration you'll know the front clutch is slipping. So, check the push-button cable adjustment. If that is okay, check line pressure. The next point would be to remove the transmission oil pan; have someone push each push button while you check to be sure the detent ball seats firmly in each position.

If everything is right up to this point, the only thing left is to disassemble and inspect the front clutch. Check for wear, and be sure the clutch is properly assembled.

Kickdown Band Test. If the kickdown band is slipping it can cause engine runaway on the 2-3 upshift, and on the 3-2 kickdown. To check the kickdown band, push in the No. 2 button and increase road speed to 20 m.p.h. The transmission should upshift to 2nd gear which means the kickdown band is applied. Accelerate quickly, with

$\frac{3}{4}$ -throttle opening, to put a heavy load on the kickdown band. If car speed responds quickly without any engine runaway, the band isn't slipping. But if there *is* engine runaway, and your test showed that the front clutch was in good condition, the kickdown band is probably slipping.

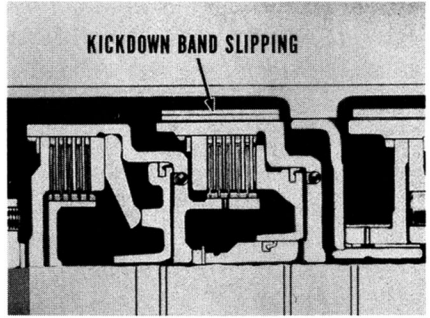

A kickdown band that's too tight can cause a harsh 2-3 upshift, and a harsh 3-2 kickdown. Check the 2-3 upshift at half-throttle. The upshift at half-throttle opening should be very smooth if the band and throttle linkage adjustments are correct. If, however, the upshift is noticeably harsh at half-throttle, the kickdown band is very likely too tight, and should be adjusted.

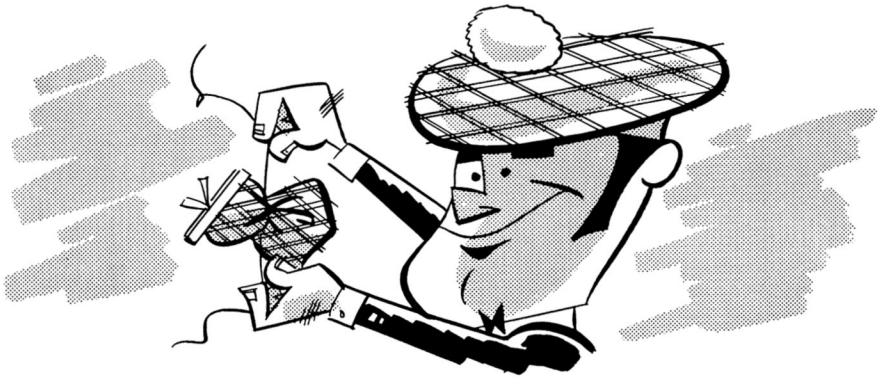

At $\frac{3}{4}$ -throttle to full-throttle, the upshift should be *firm*. It's normal for the upshift to become more noticeable as throttle opening increases.

Here's something else. Downshift at these speeds should be smooth. If it isn't, or there is engine runaway, check for a wide band adjustment.

Kickdown Band Adjustment Tips. Before you adjust any kickdown band, check the *transmission assembly number*. Final adjustment is accomplished by backing off the adjusting screw $3\frac{1}{2}$ turns, or $2\frac{1}{4}$ turns, as specified in the following chart of assembly numbers.

<u>$2\frac{1}{4}$ Turns</u>	<u>$3\frac{1}{2}$ Turns</u>
1671747	1736546
1736544	1823682
1738227	1823738
1823593	1823740
1823734	1853693
1823736	1843704
1823949	

To compensate for initial wear-in, a *new* band must be adjusted $\frac{1}{4}$ -turn tighter than specified.

If you find that the proper kickdown band adjustment doesn't correct band slippage you'll then have to check hydraulic control pressures. This is explained under the section headed "HYDRAULIC PRESSURE TESTS".

Rear Clutch Slippage. If there's pronounced rear clutch slippage on heavy throttle acceleration with the transmission upshifted in direct, the clutch pack is probably close to complete failure. You can test for this as follows:

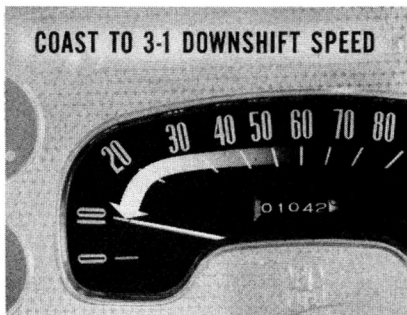

Let the car coast down until you find the speed at which the 3-1 downshift is made. Do this again. But just before the unit makes the downshift, accelerate rapidly with $\frac{3}{4}$ -throttle. If the engine races because engine speed increases faster than car speed, the rear clutch is slipping.

Rear clutch slippage may be due to leakage, or to low hydraulic pressure that takes place only during the 2-3 upshift. This may not show up when you check rear clutch pressure after the upshift.

In a case like this, about all you can do when slippage occurs in Drive is to make sure the front clutch operates properly. Also, see that rear clutch pressure is up to specifications before you disassemble the unit to locate and correct the cause of failure. So, if rear clutch slippage is obvious, the clutch is probably ruined. The wise thing would be to *correct the cause of failure* before installing a new rear clutch.

Low and Reverse Band. The rear clutch and the rear band (low and reverse band) are applied when the unit is in Reverse. If operation is okay in Drive, but there is slippage in Reverse, the rear clutch is probably okay and you should check the rear band adjustment. If you should find that correct adjustment of the rear band doesn't correct slippage, make the hydraulic pressure checks as outlined in the following text.

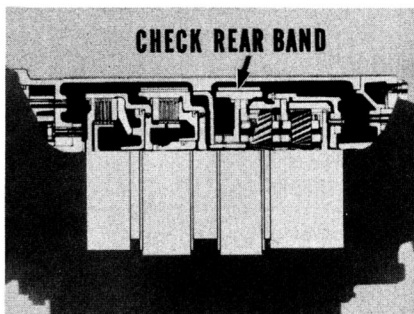

HYDRAULIC PRESSURE TESTS

As you probably know, it's easier to check pressures than to drain the unit and remove the valve body. What's more, if you check pressures first, you'll know what to look for when you disassemble and inspect the parts.

When you check pressures, the car must be on a hoist so the rear wheels are free to turn. Also, remember that the transmission fluid must be at normal operating temperature—from 160° to 180° F.

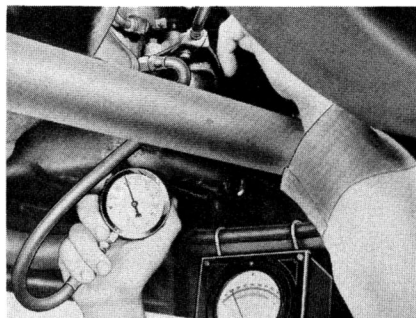
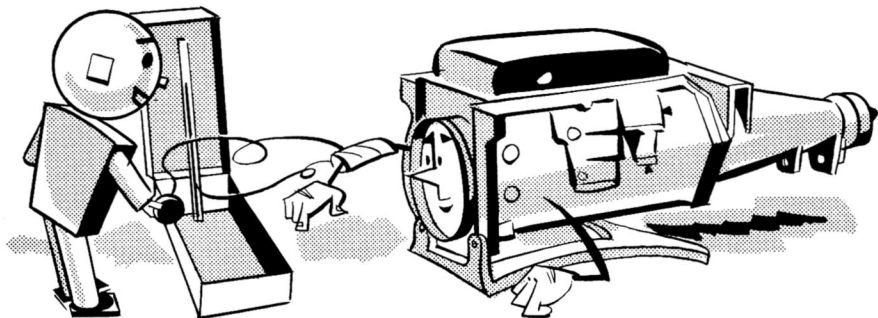

Line Pressure. Connect a tachometer to the engine. Remove the pipe plug from the line pressure take-off hole (on the left side of the transmission just below the push-button cable ferrule). Install a 300-psi gauge (C-3293). Line pressure readings and push-button positions are in the table below:

Push-Button Position	Rear Wheels	Engine Speed (r.p.m.)	Line Pressure (psi)
R	Free to turn	1600	200 - 240
N		1200	85 - 91
D	Free to turn	1200	89 - 91
2	Free to turn	1200	85 - 91
1	Free to turn	1200	85 - 91
D	Free to turn	3000	93 - 98

If line pressure isn't within the limits specified, run the engine at 1200 r.p.m., rear wheels free to turn, and with the "D" button engaged. Loosen the locknut on the adjusting screw. Turn the adjusting screw clockwise to increase pressure, counterclockwise to decrease pressure until it falls within the range of 89 to 91 psi. After adjustment, recheck line pressure at each speed and push-button position listed in the table above.

As a check on leakage run the engine at 2000 r.p.m., "D" button engaged. Decrease engine speed to 800 r.p.m. If line pressure *drops below 80 psi*, that means that there is excessive leakage in the front or rear clutch circuits, or that there is excessive side clearance at the front pump.

Governor Pressure. The following method of checking governor pressure and governor operation has proven unusually easy and accurate. Install the 100-pound test gauge at the pressure take-off hole located on the lower left side of the output shaft support. Connect an engine tachometer. With this method, pressures are to be checked at selected *engine speeds* rather than speedometer or road speeds.

The engine and transmission must be warmed up to operating temperature. Car on a lift with wheels free to turn (no brake drag on rear wheels), and "D" button engaged. Check pressures against engine speed. Make the 2400 r.p.m. check first, the 1600 r.p.m. check and then the 1000 r.p.m. check. Pressures should fall within the ranges given.

GOVERNOR PRESSURE		
Engine Speed (r.p.m.)	All Models (Except high-performance) (psi)	High-performance Models (psi)
2400	63 - 71	56 - 63
1600	46 - 52	39 - 45
1000	25 - 31	17 - 22

To check governor action, accelerate gradually from 1000 to 2400 r.p.m. and then decelerate gradually to idle again. Pressure should increase and decrease smoothly with changes in engine speed. Sudden jumps in pressure indicate a sticking governor valve.

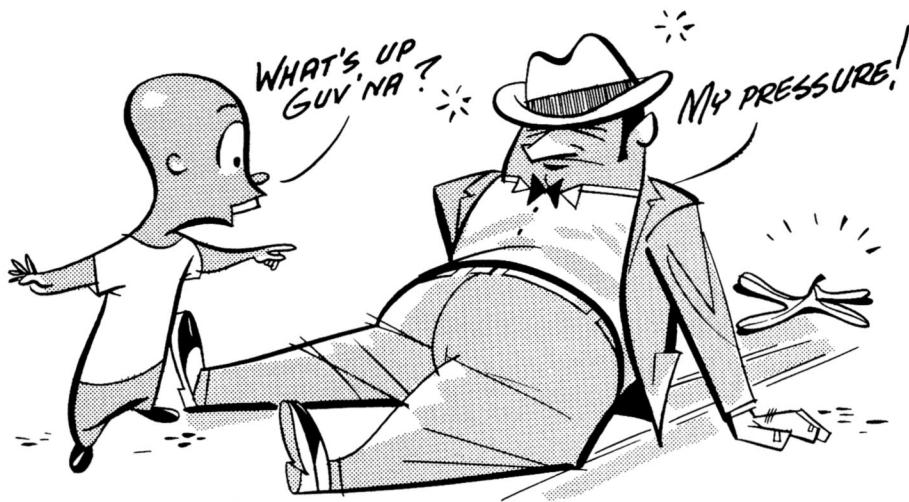

As a final check, operate the engine at normal idle speed, parking brake applied so that the drive shaft cannot turn. Pressure should not be more than 2 psi. If pressure is greater than 2 psi, you'll know that the governor valve is sticking or not properly positioned.

Lubrication Pressure. Checking lubrication pressure can provide a clue to possible internal leakage. Just remove the lower oil cooler fitting from the left side of the transmission case. Install a tee-fitting so you can connect the 100-psi gauge (C-3292). Engage the "D" button. Run the engine at 1200 r.p.m. with the rear wheels free to turn. Pressure should range from 20 to 40 psi.

Pressure much higher than 40 psi (45 psi or more) indicates excessive front clutch pressure leakage into the lubrication circuit. Lubrication pressure less than 20 psi indicates excessive internal leakage.

Compensated Throttle Pressure. Install the 100-psi gauge (C-3292) at the throttle pressure take-off on the right side of the transmission case. Disconnect the bell-crank-to-transmission-throttle-linkage at the transmission. Engage the "D" button.

Now, while holding the transmission throttle lever toward closed throttle position, increase engine speed slowly to about 1500 r.p.m.

so the unit upshifts into Direct Drive. After the upshift, compensated throttle pressure should be 26 to 32 psi.

Next . . . slowly advance the transmission throttle lever toward full-throttle position. Compensated throttle pressure should begin to rise after about 5° movement of the lever.

If pressure is above 32 psi with the lever against the internal stop (closed throttle) and pressure increases quickly when the lever is advanced, throttle pressure needs adjustment. Also, if pressure is within 26 to 32 psi but fails to rise after the 5° movement of the lever, throttle pressure should be adjusted.

Before stopping the engine, advance the throttle lever slowly to ¾ open-throttle position. Compensated throttle pressure should rise so it reads from 80 to 90 psi. Then, move the lever to closed-throttle position. Pressure should fall smoothly without hesitation to a constant minimum reading. Repeat this test several times. Your reading should be the same each time the lever's moved to closed-throttle position.

Failure to pass these tests points to a sticky compensator valve or throttle valve operation. That calls for removing the valve body assembly, thorough cleaning and inspection. Then repeat the test before trying to adjust compensated throttle pressure as outlined in the shop manual for the model you're working on.

NOTE: When the governor compensator valve (on a transmission so equipped) is removed for cleaning, inspect it for sharp corners. If there's any amount of chamfer on the edges of the lands, replace the valve.

Rear Clutch Pressure. Always check line and compensated throttle pressures and make sure that they're correct before checking rear clutch pressure. Install the 100-psi gauge at the rear clutch plug located on the left side of the transmission (just below the governor take-off). Engage the "D" button.

With the engine running at about 1500 r.p.m. so there's an upshift to direct ratio, rear clutch pressure should be not less than 75 psi.

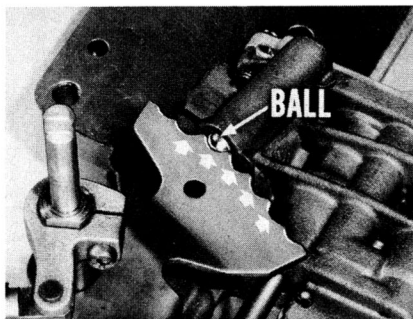

NOTE: If all pressures check out okay, but there still seems to be some slippage, double-check the push-button cable adjustment. You may have to remove the oil pan *to make sure the ball seats properly in each detent!*

ROAD-TEST FOR OVER-ALL PERFORMANCE

Every TorqueFlite job doesn't require a complete road test. But a complete road test is a good idea if you want to be sure that the transmission is working properly under all conditions. Also, a customer may need to be convinced that you've done all that can be done to provide him with the performance designed into the unit. In either case, here are the tests you'll want to make on the road.

Neutral. Engage the "N" button. There should be no creep. Increase engine speed to about 1500 r.p.m. Again, there should be no tendency to creep. If the car does move forward, check the push-button cable adjustment.

Neutral to Drive—Neutral to Reverse. At normal engine idle speed, shift from "N" to "D" and from "N" to "R" several times. There should be prompt, smooth shift every time. At light throttle opening, shift from "D" to "R" and from "R" to "D". The shifts should take place immediately.



Shift Quality

Drive. At light throttle opening, gradually increase speed to 20 m.p.h. The 1-2 shift should occur at approximately 7 to 11 m.p.h. A slight bump isn't unusual, but if the shift is harsh or has a "dragged-out" feeling (plus a bump), the throttle linkage is improperly adjusted.

The 2-3 shift should take place in approximately the 11 to 17 m.p.h. range. It shouldn't be harsh, and there should be no engine runaway. Quality here is also affected by throttle linkage adjustment.

Shifts at half-throttle opening should be *very smooth*. A normal 2-3 shift near wide-open throttle may be firm to sharp. There should be no engine runaway.

3-2 and 3-1 Kickdowns. Check quality of this kickdown at 35 and 45 m.p.h. Also, check 3-1 kickdown at 15 and 25 m.p.h. With fully depressed accelerator pedal, the downshift should be firm yet smooth, and with no engine runaway.

Closed Throttle 3-1 Downshift. TorqueFlite is designed to automatically downshift at 6 to 8 m.p.h. At closed throttle, downshift is from Direct Drive to first gear without going through the second gear. Since this downshift can't be felt, you won't know whether or not it has taken place until you accelerate from a stop, or from very low road speed.

If the downshift hasn't taken place, car performance will be very sluggish as you accelerate. Throttle opening may force the downshift, causing a bump, and followed by normal acceleration. This 3-1 downshift failure is caused by sticking of the governor compensator valve (on units so equipped), the 1-2 shift valve, the 2-3 shift valve, or the governor valve assembly.

Button-Selected Shift Tests. When the transmission's in "D" and upshifted, engage the number "2" button at 45 m.p.h. The unit should downshift *smoothly* to second gear.

Reduce speed to 25 m.p.h. and engage the number "1" button. There should be a downshift to Low gear. Come to a full stop and then accelerate to 35 m.p.h. There should be no upshift. Come to a full stop and engage the number "2" button. With light throttle opening, increase speed to 15 m.p.h. There should be an upshift to second gear at 7 to 11 m.p.h.

Reverse. At engine idle with the "N" button pushed in, engage the "R" button. The transmission should shift into reverse smoothly. Try several quick, light throttle accelerations to test for reverse band or rear clutch slippage.

If the transmission works satisfactorily except for quality of shift, check the throttle linkage adjustment first. If this is correct, then check the push-button cable and band adjustments, and finally, hydraulic pressures before making any disassembly.

Filler Tube Fluid Blowouts. Any evidence of fluid blowout from the filler tube may be due to:

1. Insufficient venting. Check vent fitting for dirt or undercoating.
2. Too high fluid level, causing "foaming" when unit is hot.
3. Converter valve stuck.
4. Front or rear pumps sucking air due to case or pump housing porosity.
5. Internal vent hole in rear support not open.
6. Water in fluid (leaking cooler).
7. Rear clutch failure causing slippage.

Most of the fluid blowouts are caused by high-speed driving and “foaming” (due to 2 and 4 above) combined with a sudden stop, or converter drainback when the car is parked for several hours. To correct blowout, install a vent fitting of greater capacity which will relieve sudden pressure build-up.

SUMMARY

Keep in mind that proper fluid level, throttle linkage and push-button cable adjustments will correct the majority of TorqueFlite malfunctions. If they don't, then road-test to find out which clutch or band might be at fault. And, to find out why a band or clutch isn't acting right, check band adjustments and make a complete pressure check before taking anything apart. Tackling TorqueFlite difficulties in this way will save time, effort, and prevent unnecessary replacement of parts. You'll feel better about TorqueFlite service, too.

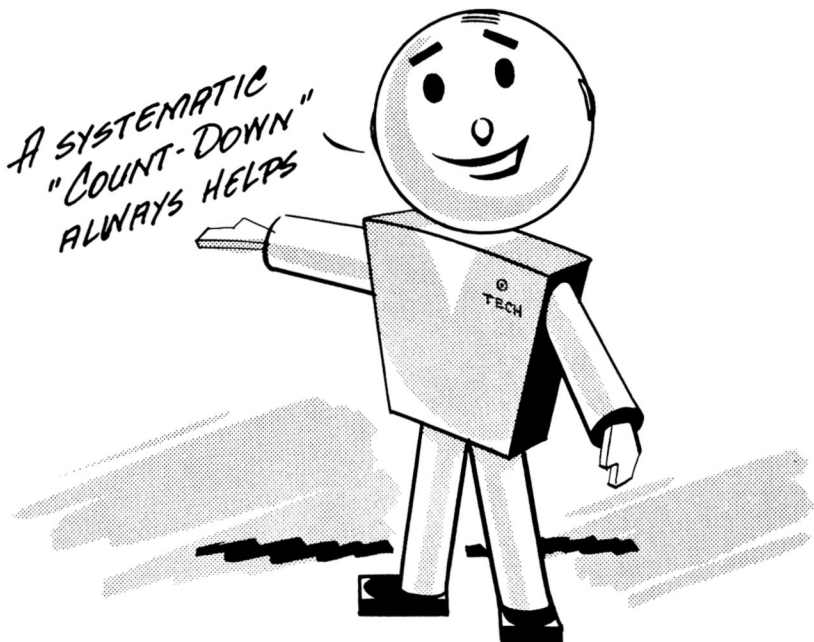

**RECORD YOUR ANSWERS
TO THESE QUESTIONS
ON QUESTIONNAIRE NO. 129**

By looking for the one band or clutch that may be at fault and isolating it, you simplify TorqueFlite service.



RIGHT

1



WRONG

Most TorqueFlite difficulties can be corrected by checking fluid level, throttle linkage and push-button cable adjustments.



RIGHT

2



WRONG

Before checking fluid level, operate all five push buttons slowly, returning to Neutral each time so all fluid passages are filled.



RIGHT

3



WRONG

When the transmission fluid is cold, the level should be at the LOW mark, plus or minus 1/4".



RIGHT

4



WRONG

When the transmission fluid is at normal operating temperature, the level should be at FULL, or 1/2" below.



RIGHT

5



WRONG

Many cases of harsh shifting and clutch slippage during acceleration can be traced to an incorrect throttle linkage adjustment.



RIGHT

6



WRONG

If throttle pressure gets too high in relation to engine torque, it will cause rough, harsh shifts.



RIGHT

7



WRONG

An incorrect push-button cable adjustment often causes poor shift quality, engine runaway, and clutch slippage.



RIGHT

8



WRONG

If a band grabs, the shift is harsh; and if a band or clutch slips, there will be engine runaway during a shift.



RIGHT

9



WRONG

A kickdown band too tight can cause a harsh 2-3 upshift and 3-2 kickdown.



RIGHT

10



WRONG