

SERVICE REFERENCE BOOK

of the **MASTER TECHNICIANS SERVICE CONFERENCE**

session no.

157

SERVICING OPERATING CONTROLS

Prepared by CHRYSLER CORPORATION
PLYMOUTH, DODGE, CHRYSLER-IMPERIAL DIVISIONS

**TECH
SEZ:**

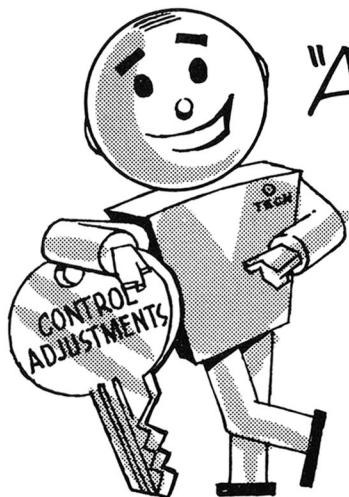

"Adjustment of controls
is the key to
proper operation
of the unit"

Sometimes we are so close to the picture we can't see the over-all view—which is another way of saying we can become so concerned with the internal operation of a unit we often overlook the fact that the unit operates in response to external controls.

A condition which appears to be caused by some internal malfunction is often caused by the incorrect adjustment of the control assembly—cable, linkage or whatever means is used to control the operation of the unit. Many times a readjustment of the control assembly will correct the condition and save a technician a lot of trouble.

This reference book covers the adjusting procedures applied to a number of control assemblies for the operation of such units as the transmission, steering gear and parking lock.

TABLE OF CONTENTS

	<i>Page No.</i>
TORQUEFLITE TRANSMISSION CONTROLS	4
GENERAL	4
FLUID LEVEL	5
PUSHBUTTON CABLE ADJUSTMENT—	
TORQUEFLITE TRANSMISSION	5

	Page No.
THROTTLE LINKAGE ADJUSTMENT	7
Eight-Cylinder Models	7
Valiant and Lancer (170 Cu. In.)	
TorqueFlite Six	9
Plymouth and Dart (225 Cu. In.)	
TorqueFlite Six	11
MANUAL TRANSMISSION CONTROLS	12
GEARSHIFT LINKAGE ADJUSTMENT	14
Column-Mounted Linkage	14
Heavy-Duty Linkage—Plymouth and Dart Models	16
Floor-Mounted Linkage—Valiant, Lancer	
and Chrysler 300-G	18
CLUTCH	20
VALIANT AND LANCER MODELS	20
OTHER MODELS	20
POWER STEERING	21
HARD STEERING	21
POOR RECOVERY	22
MANUAL STEERING	22
HARD STEERING—POOR RECOVERY	22
PULLING TO ONE SIDE	23
EXCESSIVE PLAY IN WHEEL	23
PARKING BRAKE	24
VALIANT AND LANCER	24
Adjusting the Cable	24
TRANSMISSION PARKING LOCK	25
VALIANT AND LANCER MODELS	25
Cable Adjustment	25
Pushbutton Housing Bench Tests	28
Neutral Slide Pin Adjustment	29
Actuator Lever Stop Adjustment	30
CONCLUSION	31

TORQUEFLITE TRANSMISSION CONTROLS

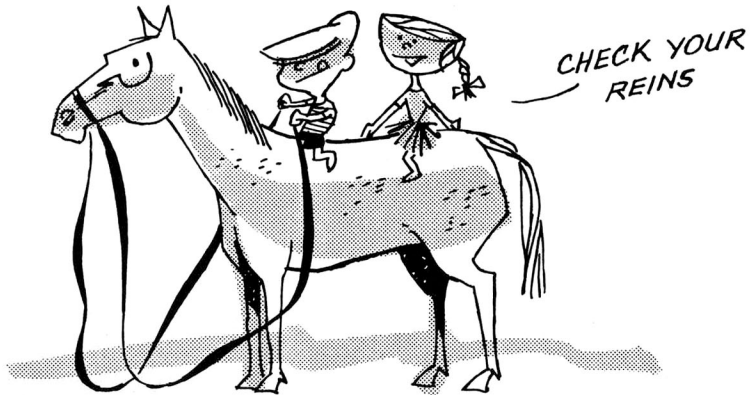

General

Assuming that the engine is operating properly, the correct fluid level in the transmission and the proper adjustment of the pushbutton cable and the throttle linkage are the principal factors in smooth, positive performance of the automatic transmission.

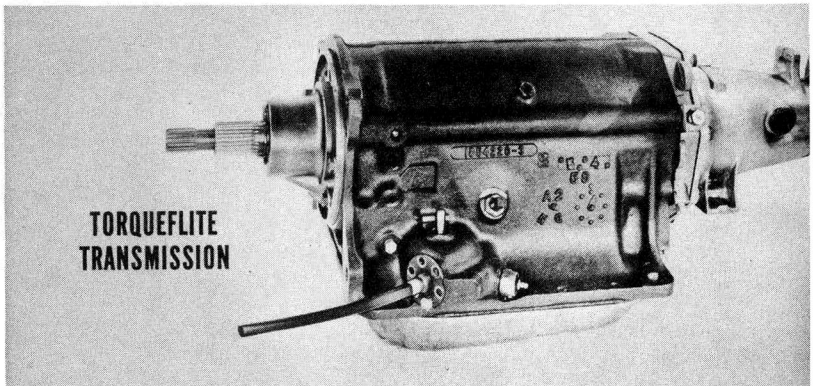

If the owner should report that the TorqueFlite transmission in his car shifts erratically or tends to run away on upshift, the three most

likely causes should be considered in this order: (1) Improper fluid level, (2) improper adjustment of the pushbutton cable, and (3) improper adjustment of the throttle linkage.

Fluid level

Since the transmission depends upon hydraulic pressures to operate the bands, clutches and servos, it is important that the fluid level be between the Low and Full marks on the dipstick with the fluid warmed up to operating temperature and the engine idling. If the level is low, add only sufficient Automatic Transmission Fluid—Type A, Suffix “A”, to bring the level up to the prescribed mark. Never *overfill* the transmission as this could result in the fluid foaming and aggravating the difficulty.

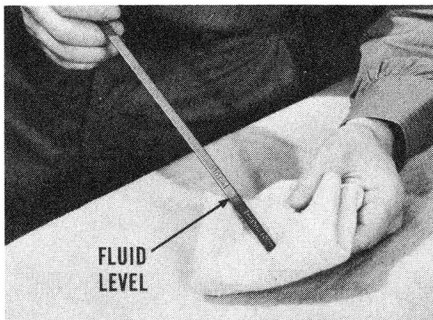

Pushbutton cable adjustment— TorqueFlite transmission

The correct adjustment of the pushbutton cable is important to the proper operation of the transmission. If the cable is not properly adjusted, the notches in the manual valve lever will not line up with the spring-loaded detent ball. Further, if the valve is too far out of position, it can restrict the flow of fluid to the clutches and servos. In addition to affecting the over-all operation of the transmission, the restricted flow of fluid could damage the clutches and servos.

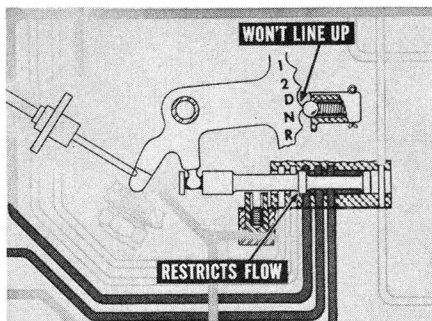

The cable is adjusted by the adjusting wheel threaded on the transmission end of the cable.

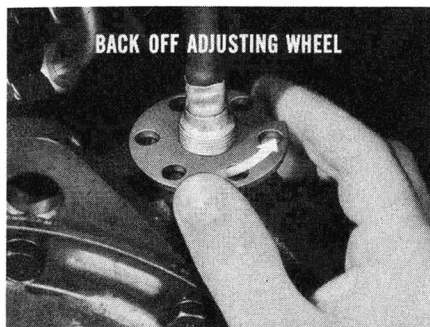

To adjust the cable, first back off the adjusting wheel a couple of turns. If the wheel turns hard, examine the threads on the cable for dirt or burrs. After removing any obstructions from the threads, apply a few drops of automatic transmission fluid to the threads.

Then, with a helper holding the "R" button in, push the cable in

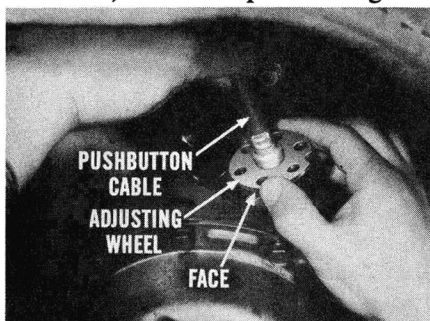

with only enough force so that it just bottoms in the cable adapter. Hold it in that position, and turn the adjusting wheel clockwise until the full surface of the wheel *just touches* the face of the case. It is important that the cable be held at right angles to the machined surface of the case so

the full surface of the wheel is flat against the case.

If one of the holes in the wheel lines up with the screw hole in the case, turn the wheel clockwise five holes.

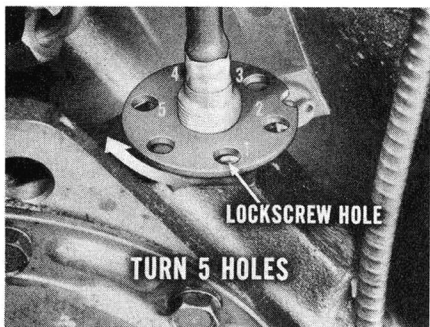

Then, install the lock-screw and tighten it. If one of the holes in the wheel does not line up with the screw hole in the case, turn the wheel clockwise until one of the holes does line up. Then, continue to turn the wheel an additional five holes, and secure it with the lock-screw.

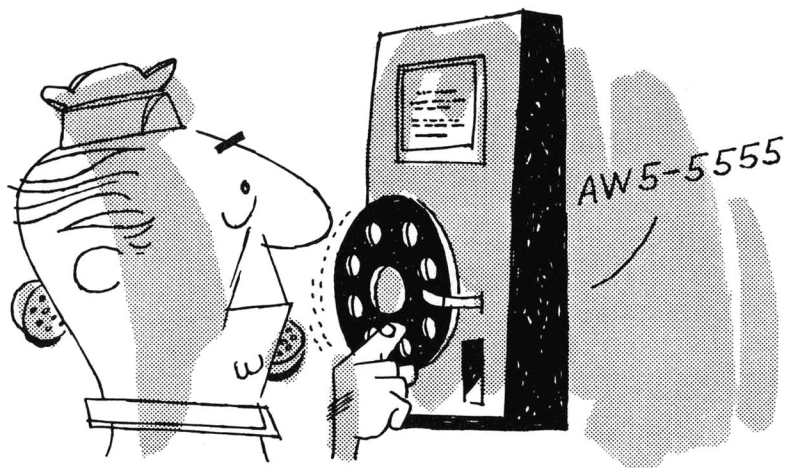

Throttle linkage adjustment

The next step would be to examine the throttle linkage setting since it controls the position of the throttle valve. The throttle valve regulates the hydraulic pressure applied to the clutches and servos in proportion to the throttle opening. Throttle pressure should vary from zero at closed throttle to about ninety pounds per square inch at wide-open throttle. Therefore, unless the throttle linkage is properly adjusted, it will not be possible to obtain the correct throttle pressure and smooth shifting. Before adjusting the throttle linkage be sure the *engine is idling smoothly*, and at the proper speed. Follow the specifications for the car on which you are working.

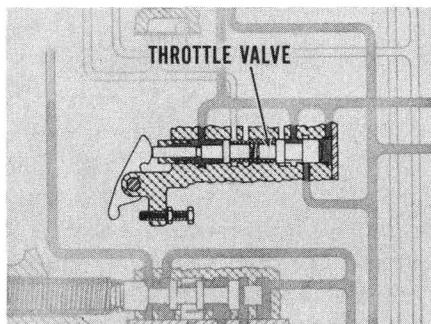

Eight-Cylinder Models. When adjusting the throttle linkage on 8-cylinder models, be sure to loosen the locknuts at the sliding joints at the carburetor and transmission ends of the linkage just enough to permit the rods to slide.

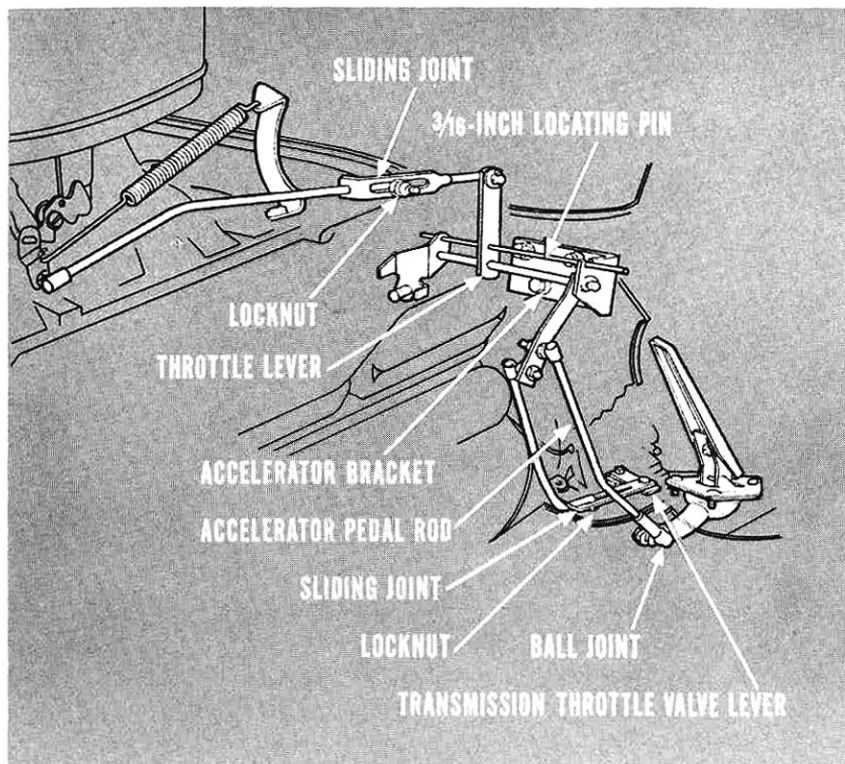

Position the throttle lever in the accelerator bracket by inserting a 3/16-inch locating pin in the hole and slot of the bracket and the hole in the lever. This will assure the throttle lever being properly located while the transmission throttle valve lever is being adjusted. With the throttle valve lever moved all the way forward against its stop, tighten the locknut in the sliding joint at the transmission end of the linkage.

Before adjusting carburetor rod at the sliding joint, remove the 3/16-inch locating pin from the accelerator bracket, freeing the throttle lever. Move the lever and rod back as far as it will go. Hold it there, and tighten the locknut at the sliding joint.

To be sure there is full travel of the throttle valve from closed throttle through kickdown, the angle of the accelerator pedal should be between 113 and 115 degrees from the horizontal. This can be measured with a protractor, or by being sure there is clearance between the pedal and the floor mat or carpet when the pedal is fully depressed. If an adjustment is necessary, it can be made at the ball joint at the lower end of the accelerator rod.

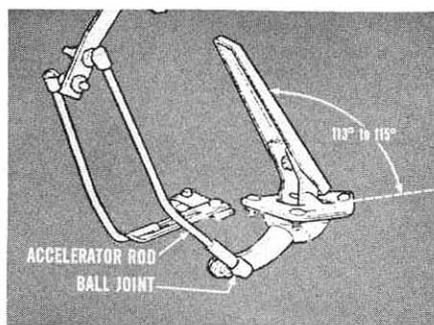

Valiant and Lancer (170 Cu. In.)—TorqueFlite Six. On these models, the first step is to disconnect the ball joint at the upper end of the accelerator shaft rod. Then, loosen the locknut at the sliding joint in the transmission rod. A 3/16-inch locating pin should then be inserted through the holes in the accelerator shaft bracket and the bell crank to hold the bell crank in position while adjusting the transmission throttle valve lever.

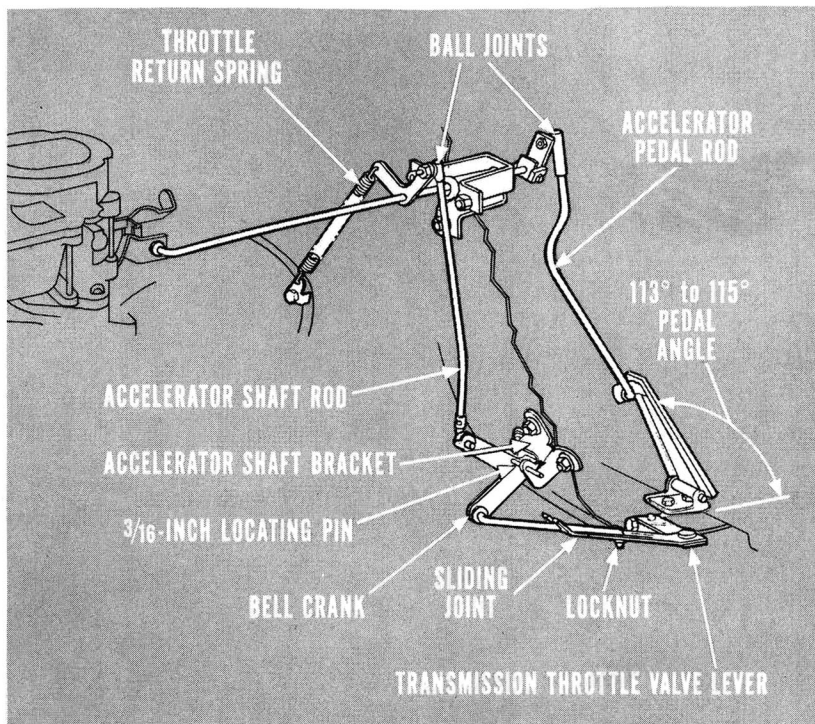

Move the transmission valve lever forward to its stop. Hold it there, and tighten the locknut.

The accelerator pedal should be at an angle of 113 to 115 degrees from the horizontal on these models also, to assure full travel of the throttle valve from closed throttle through kickdown. If an adjustment is necessary, the pedal angle can be adjusted at the ball joint located at the upper end of the accelerator rod. After this adjustment, remove the 3/16-inch locating pin from the accelerator bracket and bell crank.

With the throttle return spring attached, hold the carburetor choke valve open, and open the throttle valve slightly to release the fast-idle cam. Return the carburetor throttle valve to the curb-idle position.

The accelerator shaft rod length is adjusted at the ball joint at its upper end. The adjustment is correct if the ball socket lines up with the ball end when the rod is held upward against its stop.

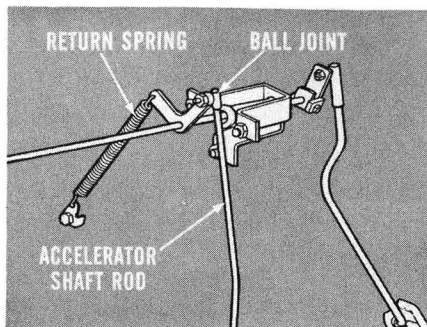

Plymouth and Dart (225 Cu. In.)—TorqueFlite Six. The throttle linkage for the TorqueFlite Six transmission is different when used with the 225-cu.-in. engine than with the 170-cu.-in. engine. To adjust the throttle linkage on these models, it is first necessary to disconnect the ball joint at the upper end of the torque shaft rod lever. Then

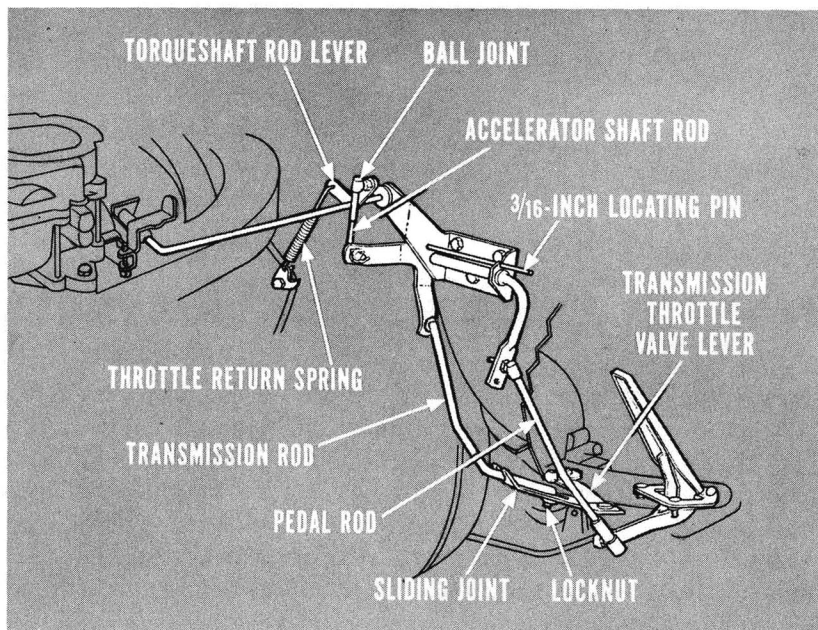

loosen the locknut at the sliding joint of the transmission rod. Insert a 3/16-inch locating pin through the holes in the bell crank and accelerator shaft bracket and lever. Move the transmission throttle valve lever forward to its stop, and tighten the locknut.

Set the accelerator pedal on these models to the same angle as for the others. Make the adjustment at the ball joint located at the lower end of the pedal rod. Then remove the locating pin from the bell crank.

Set the curb idle in the same manner as described for the Valiant and Lancer models.

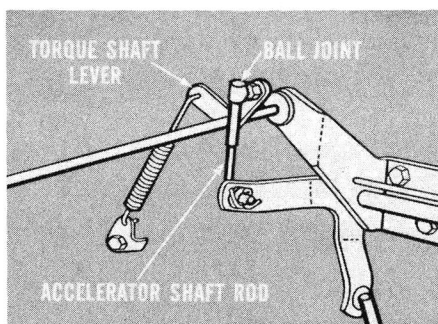

The accelerator shaft rod connecting the torque shaft lever and the accelerator rod lever is adjusted by the ball joint located at the upper end of the rod. The length is correctly adjusted if the ball socket on the rod lines up with the ball end when the rod is held upwards against the transmission stop.

MANUAL TRANSMISSION CONTROLS

There are three main difficulties that could be caused by improper adjustment of the controls of manual transmissions. These are: (1) hard shifting, (2) slipping out of gear and (3) gear clashing. These conditions may be experienced on cars using the floor-mounted controls as well as those using the steering-column-mounted controls. The cause is often due to incorrectly adjusted gearshift linkage; interference in the linkage, or an improperly adjusted clutch pedal could also cause these conditions.

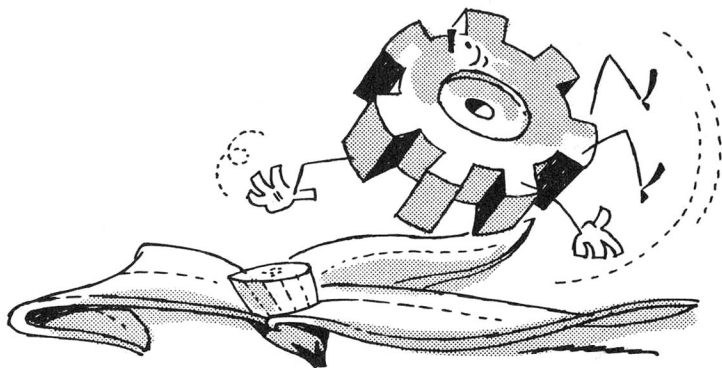

MANUAL TRANSMISSION

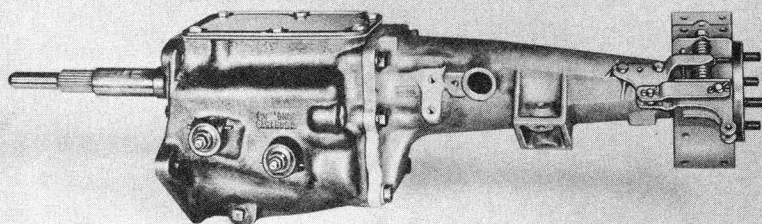

When investigating the cause of hard shifting, feel for a lumpy or binding spot as the gearshift lever is moved through the crossover. Generally, this is due to some interference between the square head on the crossover pin and the corners of the slots in the two shift levers. Any slight misalignment of the levers, due to improper adjustment of the shift rods, will place a restriction on the pin as it moves from one slot to the other.

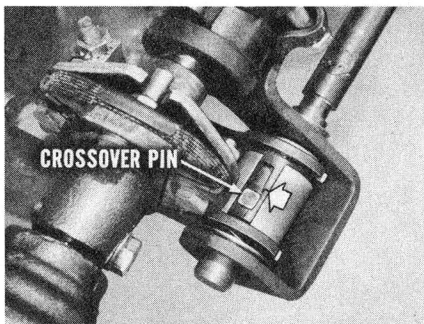

Gearshift linkage adjustment

Column-Mounted Linkage. Start the adjustment by first observing the position of the gearshift lever knob. The knob should be just about horizontal, but still provide sufficient clearance so the driver does not hit his hand against the heater pushbuttons when he shifts gears. There should also be sufficient clearance so he doesn't push the lever out of gear with his knee when he moves his foot from the accelerator pedal to the brake pedal.

If the lever requires an adjustment, the first step is to adjust the length of the low-and-reverse control rod. Adjust the two locknuts on the threaded end of the control rod to move the gearshift lever up or down until the shift lever knob is in the horizontal position. While this is being done, care should be exercised not to move the shift levers from their neutral position.

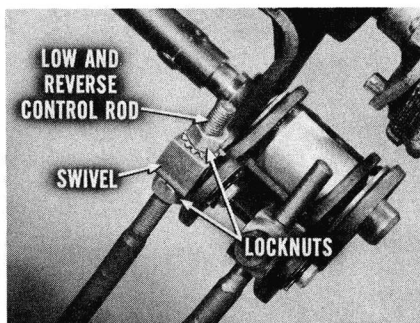

Following this adjustment, be sure that the gearshift lever has equal free play in low-gear position and in second-gear position. If it hasn't, loosen the two nuts that secure the gearshift tube lower support to the bracket and the support clamp bolt nut. Then, using a soft hammer, tap the support up or down the steering column to equalize the gearshift lever travel. Then, tighten the nuts.



If there is interference between the crossover pin and the two shift levers while shifting through the crossover, it can be corrected by adjusting the length of the second-and-direct control rod.

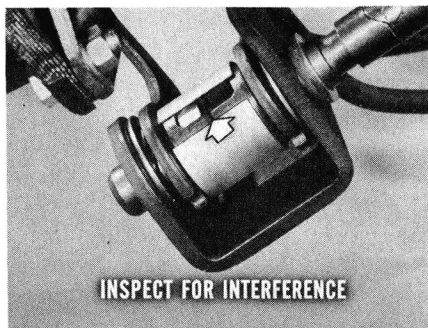

The end of this rod is smooth instead of being threaded. Also, the swivel is secured on the rod with a clamp and clamp screw instead of two locknuts.

To adjust the length of the rod, loosen the clamp screw just enough to move the shift lever and swivel on the rod. Line up the slots in the shift lever hubs so the crossover pin will slide freely. Then, tighten the clamp screw to 100 inch-pounds torque.

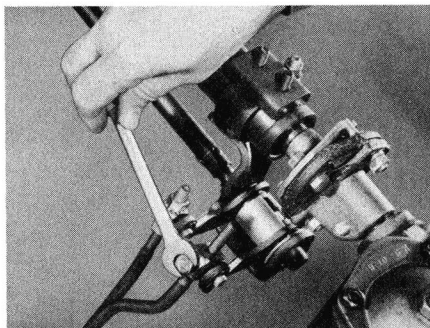

Test the linkage for interference by shifting it from one extreme to the other. If the control rods are properly adjusted, but there is still some interference, look for bent rods or levers. Straighten or replace damaged parts. Also, examine the floor pan seal to eliminate the possibility of interference due to it being out of position or distorted.

Another possibility of linkage interference is the lack of clearance with the throttle linkage when the throttle is closed. Move the gear-shift lever to all four positions to be sure no interference exists.

Heavy-Duty Linkage—Plymouth and Dart Models. Taxicabs and other vehicles, which are usually subjected to abnormal operating conditions, are provided with a transmission interlock on the column low-and-reverse shift lever. This interlock engages in a hole in the low-and-reverse shift lever and prevents transmission lockup in low gear by retaining the column lever in neutral position while shifting into second and high gear.

This device consists of a split nylon bushing located in a groove at the lower end of the shift tube, a lock spring assembled over the bushing, a lock pin and a heavier low-and-reverse shift rod. A *round* crossover pin is used instead of the square-head pin as used on other models. This is mandatory, as the use of the square-head pin will cause improper selection of gears.

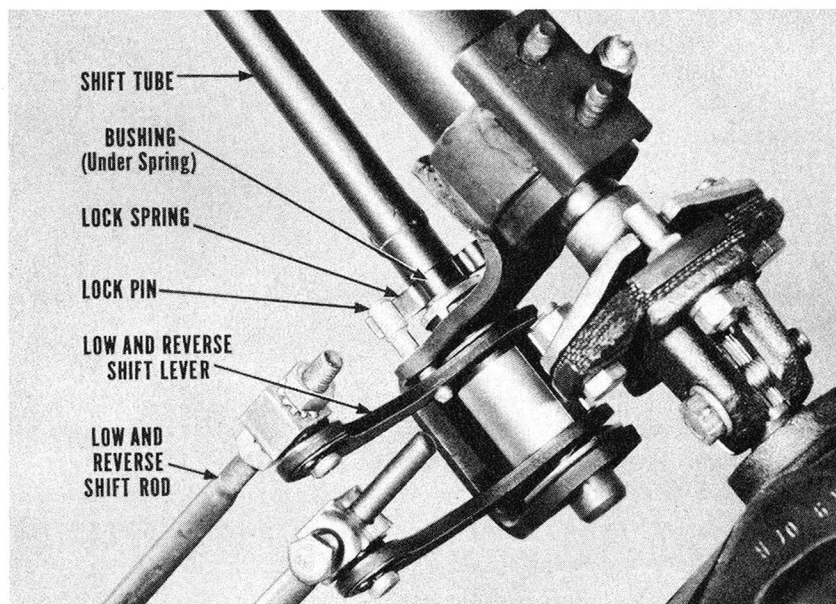

The adjustment of the interlock should be made with the engine idling, the clutch engaged and the transmission in neutral. The swivel blocks on the two shift rods should be free to move.

Raise and lower the gearshift lever to be sure the interlock pin is centered in the shift lever hole. If the gears clash while pushing the lever down, the swivel block on the rod must be moved downward. Then, tighten the locknuts.

Adjust the second-and-direct shift rod to line up the crossover pin slots in the column shift lever hubs to provide smooth travel of the crossover pin. During crossover shift, the movement of the round crossover pin from the second-and-direct lever hub to the first-and-reverse lever hub should be hardly noticeable.

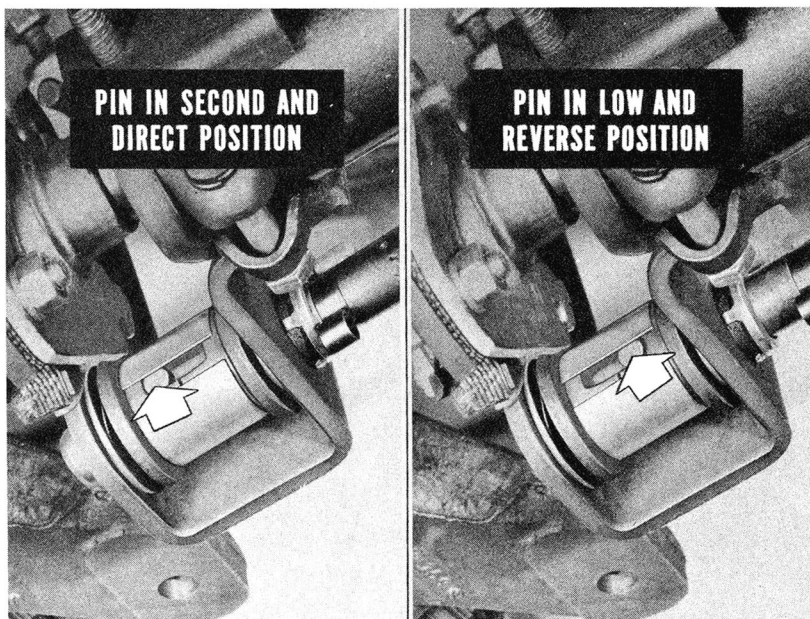

If a lumpy feeling occurs when shifting to either gear, the shift rods are not properly adjusted. When the slots are correctly lined up, tighten the swivel block clamp screw to 100 inch-pounds torque to prevent the block from shifting its position.

Rotate the pin retainer to expose the grease fitting tapped hole, and install the fitting.

Floor-Mounted Linkage—Valiant, Lancer, Chrysler 300-G. The angle of the gearshift lever on these models can be changed to suit the individual owner.

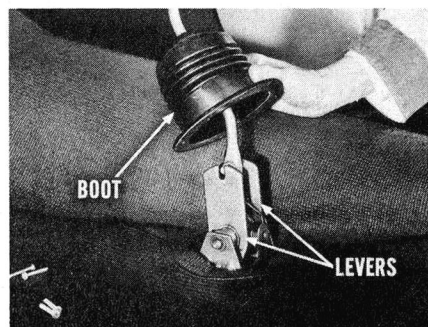
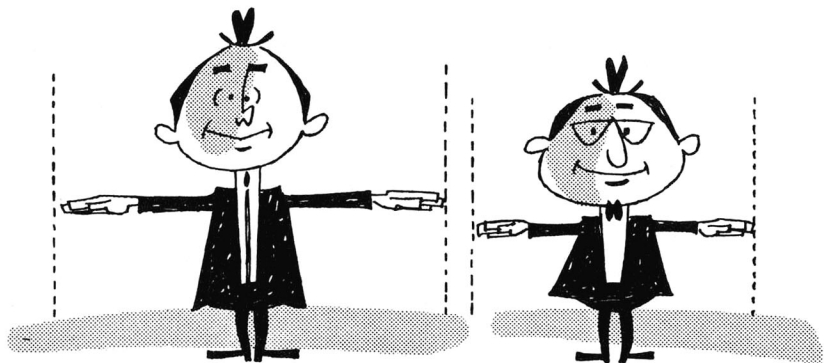

When the boot is raised to expose the levers, it will be noted that they are approximately vertical to the floor when in standard production position. The gearshift lever angle is changed by changing the length of the rods between the shift levers and the levers on the transmission.

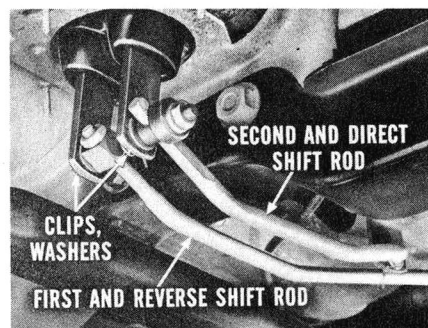

Disconnect the first-and-reverse and second-and-high shift rods from their levers by removing the spring clips, flat and wave washers.

Then move the gearshift into the position desired. Lock the lever in neutral by sliding a wedge between the fork on the gearshift lever and the second-and-high lever.

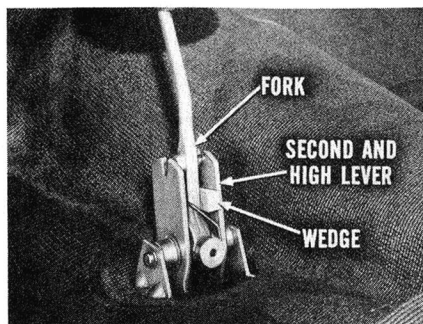

Pre-set the length of the first-and-reverse shift rod by loosening the locknut on the end of the rod. Turn the swivel block on the threaded end of the rod until the stub end can be inserted in the first-and-reverse lever. Secure the swivel block to the lever with the washers and clip.

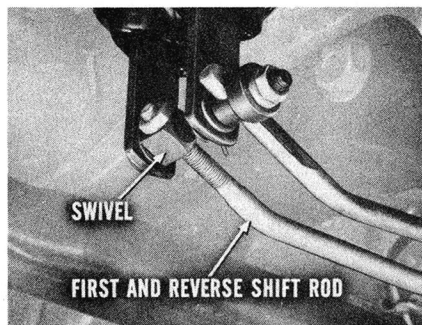

Loosen the clamping nut that holds the second-and-high shift rod in the swivel block. Slide the swivel block either to the front or rear on the rod until the stub shaft on the block can be inserted into its lever. Secure the block with the washers and clip, and tighten the clamping nut to 20 inch-pounds torque. Remove the wedge, and slide the boot back down into position.

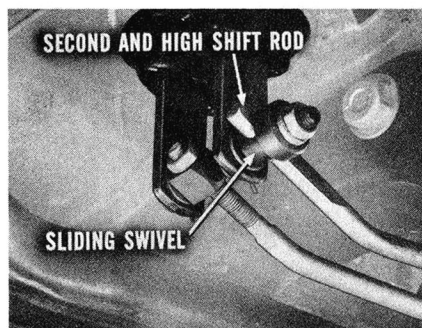

CLUTCH

Valiant and Lancer models

The clutch on these models is a single, dry-disc type with only one adjustment which compensates for normal clutch facing wear. The clutch pedal is provided with a non-adjustable over-center spring to assist the driver in depressing the pedal to disengage the clutch.

Maximum clutch life and ease of operation depend upon the proper amount of clutch pedal free play—the amount of pedal movement before the clutch starts to disengage. Shortening or lengthening the clutch release fork link by means of the adjusting nut to provide $\frac{5}{32}$ -inch free movement at the outer end of the release fork will provide the one-inch free play at the pedal.

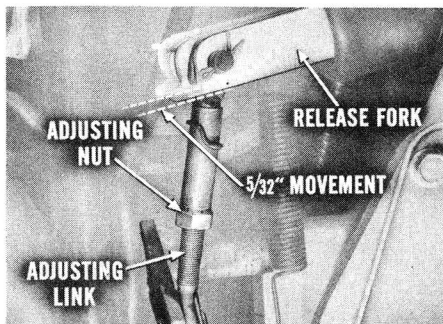

Other models

All other models using the manual transmission are also equipped with a single, dry-disc type clutch. The over-center spring used on these models is adjustable, however, and the adjustment is made the same as on prior models. The clutch pedal free-play adjustment is also made in the same manner as on prior models. By providing $\frac{5}{32}$ -in. free movement at the outer end of the release fork, one to one-and-one-quarter inches free play is provided at the clutch pedal. The adjustment is made by means of the self-locking nut on the fork rod.

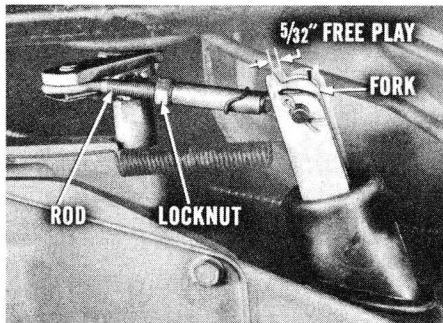

POWER STEERING

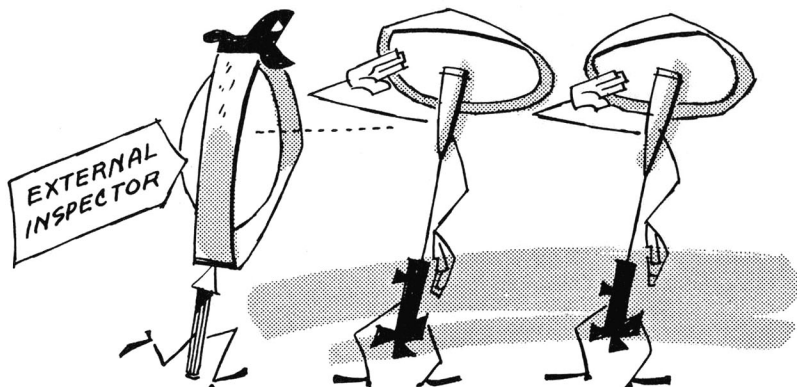

The conditions most commonly encountered with power steering, and which can usually be corrected by external adjustments are: (1) Hard steering, (2) poor recovery, (3) self-steering, (4) intermittent power assist, (5) gear chuckle and (6) excessive free play.

Not until all possibilities of correcting a condition by external adjustments have been exhausted should it become necessary to remove the power steering unit or pump for further examination and repairs.

Hard steering

When dealing with a report of hard steering, the first point to inspect is the fluid level. Be sure the fluid level is up to the bottom of the filler neck in the pump. If the fluid level is low and additional fluid is installed, with the engine running, turn the steering wheel several times from one extreme to the other to expel all air from the hydraulic system.

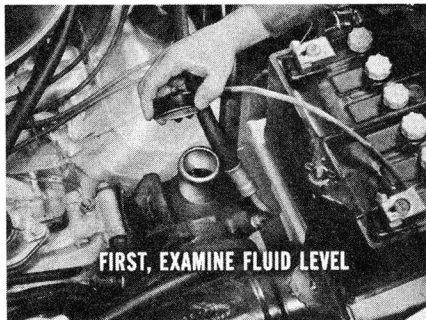

The next step is to make sure the pump belt tension is right. On models using the Load Reaction Belt Tensioner, be sure to use the torque wrench and adapter to set the belt tension. On all other models using the conventional pump mounting bracket, be sure to use the torque wrench to obtain the proper belt tension. Do not guess at belt tension.

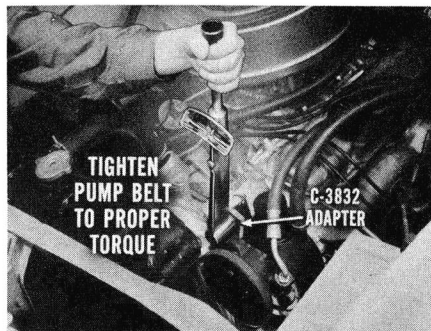

Glazed or oily pump belts that might be slipping or noisy should be replaced since they cannot be satisfactorily cleaned.

Poor recovery

On reports of poor recovery from turns, look into these possibilities: (1) Low or uneven tire pressures, (2) improper front-end alignment, (3) improper gear shaft adjustment and (4) binding or worn steering linkage. Pump pressure could also contribute to poor recovery.

MANUAL STEERING

Hard steering—Poor recovery

In dealing with reports of hard steering and poor recovery from turns, the following conditions should be inspected: (1) Low and uneven tire pressures, (2) lack of lubricant in the housing or linkage, (3) improper gear shaft adjustment, (4) improper front-end alignment and (5) misalignment of the steering column in relation to the tube. If these operations are performed in the order given, it is likely the cause of the trouble can be located before all of them are performed, resulting in a saving of time and expense.

Pulling to one side

In the case of a report of the car pulling to one side, the first item to test would be tire pressure to be sure all four tires are up to specifications. The next step would be to test brake adjustments and, finally, front-end height and alignment. There is a good possibility that performing one of these operations may correct the condition.

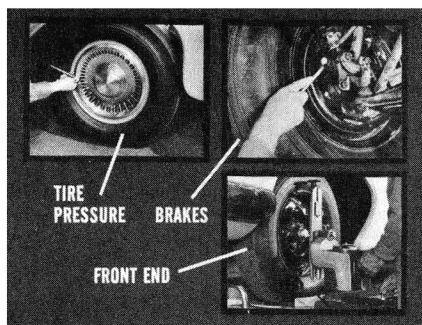

Excessive play in wheel

In the case of excessive play in the steering wheel, the first thing to do is tighten the coupling clamp bolt. Then eliminate all play in the steering linkage. If these steps do not correct the difficulty, the next thing to do would be to adjust the gear shaft.

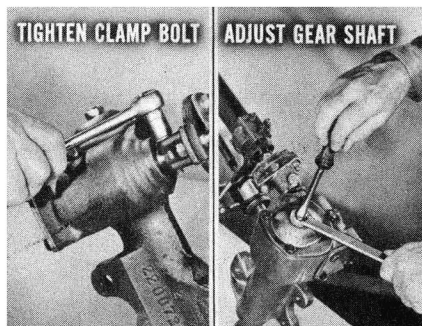

It is understood, of course, that if external adjustments do not provide satisfactory results, there is no alternative except to remove and disassemble the unit for further examination and repair.

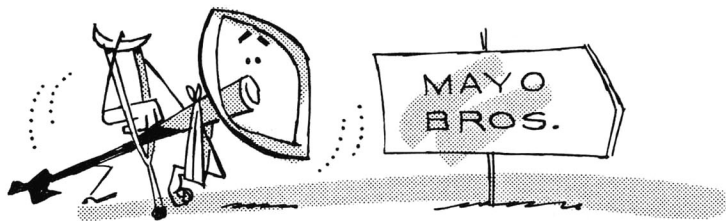

PARKING BRAKE

Valiant and Lancer

The new simplified parking brake cable arrangement used on these models has only one adjustment point and that is the adjusting nut on the front cable to the rear of the equalizer.

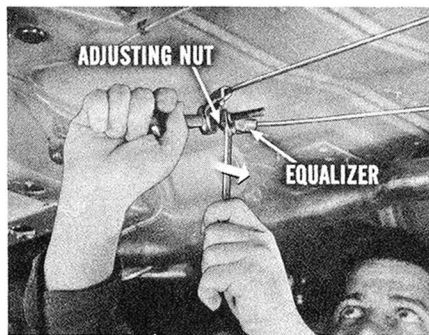
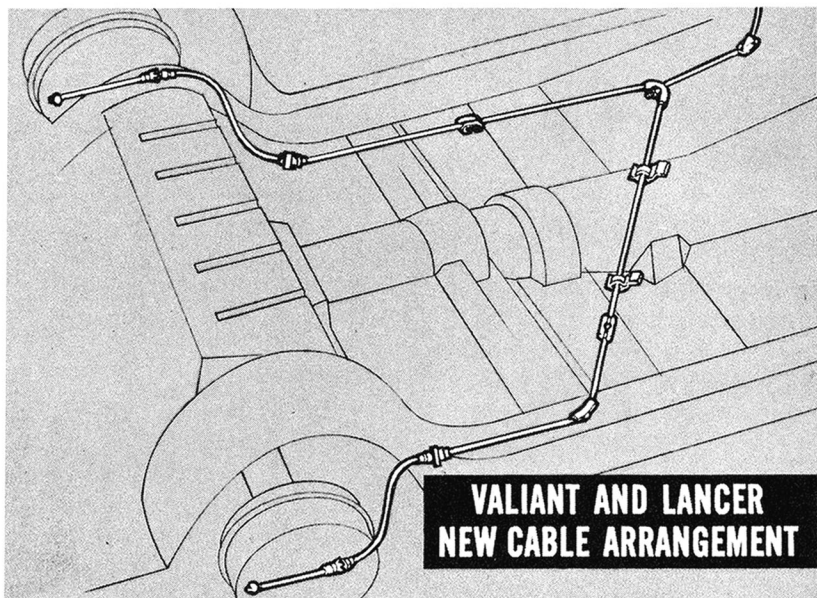

Adjusting the Cable. The first step is to release the parking lever. Then, slack off the cable by loosening the adjusting nut and the locknut in front of the equalizer. Next, adjust the rear brake shoes.

Following this, tighten the adjusting nut until the rear wheels are difficult to turn. Then, loosen the adjusting nut just enough to allow the wheels to turn freely without dragging. If some drag persists at one wheel, apply the brake two or three times to equalize the cable. Then, tighten the lock-nut in this position. Test the wheels again to be sure they turn freely.



TRANSMISSION PARKING LOCK

Valiant and Lancer models

An occasional report may be received of the parking brake lock not holding, or only partially engaging, resulting in a ratcheting noise. These conditions can best be tested by placing the car on an incline, and applying the parking lock.

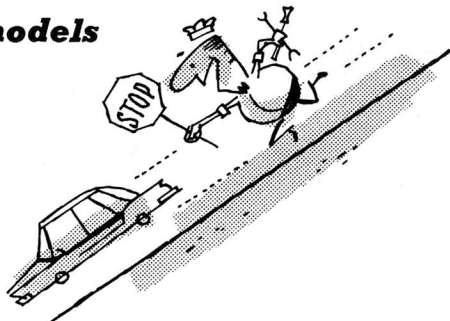

Cable Adjustment. If an adjustment is required, operate the locking lever from one end of the slot in the instrument panel to the other. The lever should have clearance at both ends. If it doesn't, the travel can be adjusted by working from behind the instrument panel.

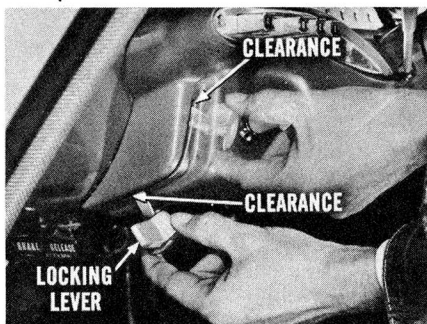

Move the lever to the fully "off" position. Then, loosen the two nuts ($\frac{7}{16}$ " wrench) which attach the locking lever to the actuator

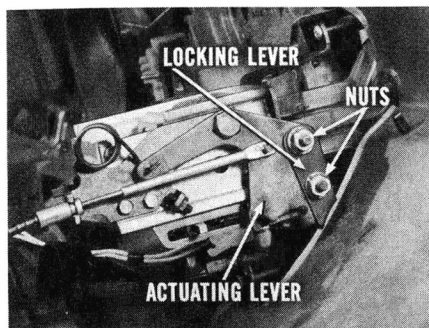

lever on the side of the push-button housing. Loosen the upper nut just enough to free up the locking lever. Next, block the locking lever (or have someone hold it) $\frac{1}{16}$ -inch below the *upper* end of the lever slot. Then, tighten the two nuts on the side of the pushbutton housing.

Test the lever travel to make sure the lever moves from top to bottom of the slot without hitting either end. With the lever properly adjusted, the next step is to adjust the cable at the transmission end.

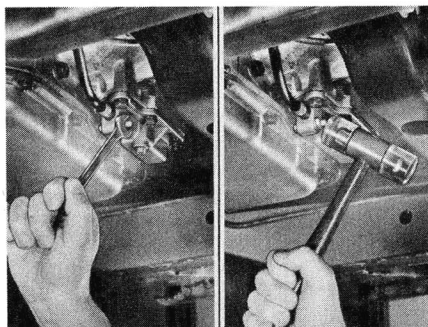

Move the locking lever to the "off" position. Loosen the cable clamp screw nut several turns. Tap the end of the screw lightly to release its hold on the cable. Grasp the cable with the bare hand and move it back and forth in the cover.



If the cable will not move, it is most likely due to a burr having been raised on the cable end, due to overtightening the clamp screw nut. If such is the case, use a pair of thin pliers, and grip the metal part of the cable housing just tightly enough to work the cable out of the cover while holding the adapter spring released. Then remove the burr.

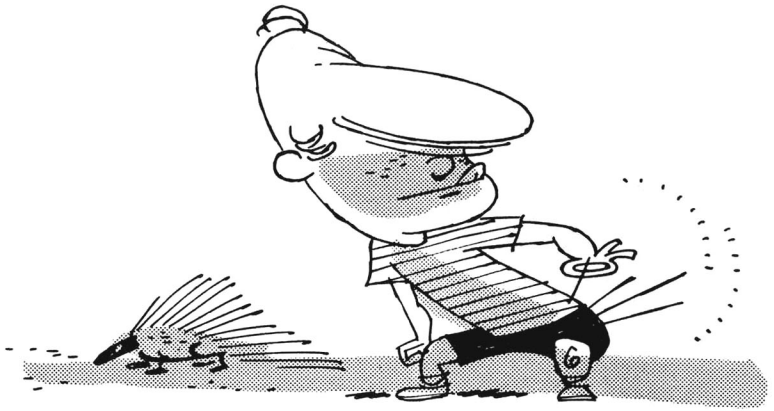

CAUTION: Do not use pliers or any other tool to grip the rubber or plastic cable covering. If you do, you'll tear it and the complete assembly will have to be replaced.

If the cable is free when the clamp screw nut is loosened, move it back and forth in the cover to be sure it is properly engaged in the adapter by the adapter spring.

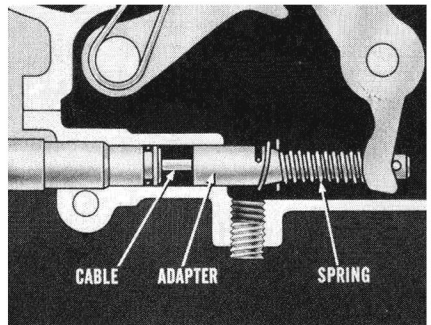

Then pull the cable out, gently, to the limit of its travel. Hold it there, and tighten the cable clamp screw nut to about 10 inch-pounds torque. Don't over-tighten it!

Examine the cable carefully to be sure it is routed so it does not touch the exhaust line. If the covering is burned, the cable will leak oil and will have to be replaced.

If the parking lock still does not work properly after making the adjustments outlined above, it will be necessary to remove the push-button housing for further adjustments.

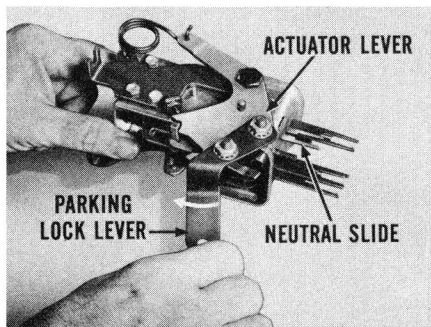
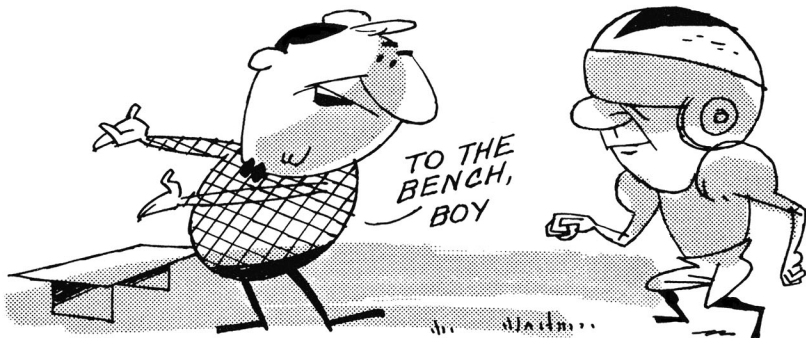

Pushbutton Housing Bench Tests. With the pushbutton housing on the bench, push the neutral pushbutton slide all the way in. Then, move the parking lock lever from top to bottom to make sure the actuator lever moves through the arc without binding.

Next, push the direct slide all the way in. Again operate the

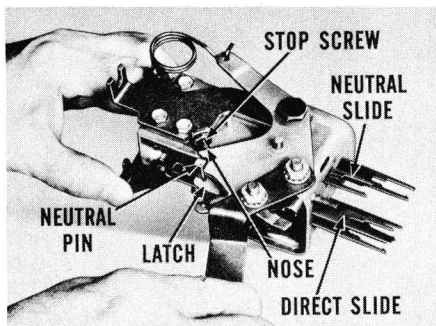

parking lock lever from top to bottom. Make sure the actuator lever moves the neutral slide pin into the neutral position. Also, make sure the neutral pin latch has engaged the neutral pin. Finally, make sure the nose of the actuator lever rests against the end of the stop screw.

If the mechanism does not function as it should in the tests, make the following adjustments.

Neutral Slide Pin Adjustment.

With the neutral slide pushed all the way in and the neutral slide pin locked, the nose of the actuator lever should rub lightly over the top of the neutral slide pin as the parking lock lever is moved toward the "PARK" position.

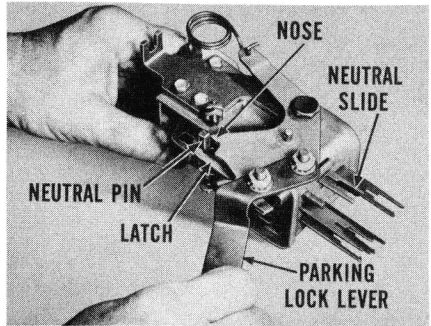

If the nose of the lever does not touch the neutral slide pin, bend the pin straight back until it does.

CAUTION: Extreme care should be exercised when bending the neutral slide pin to avoid bending the tail section of the slide which projects through the rear of the housing.

Use two pairs of pliers, one pair to hold the slide rigid just below the pin attachment point and the other pair to bend the pin. Very little movement of the pin is required to obtain the desired position.

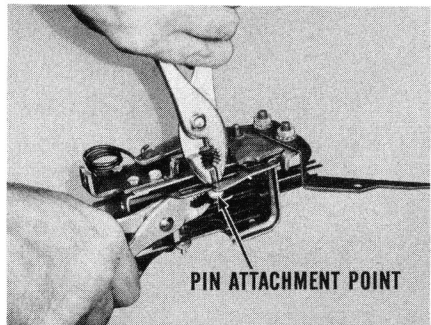

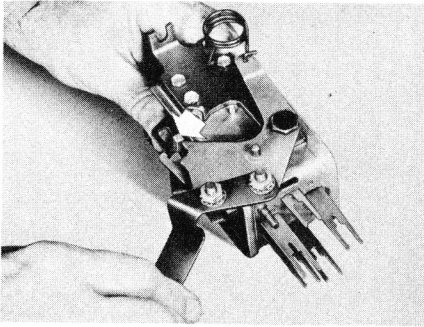

If the nose of the actuator lever strikes the neutral slide pin too low, it will not ride over the pin and lock the neutral slide in its locked position.

To correct this, bend the neutral slide pin forward to reduce the contact between the pin and the nose of the actuator lever. Use care when doing this.

Actuator Lever Stop Adjustment. Place the parking lock lever in the

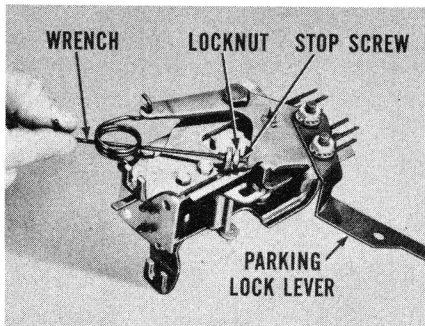

“PARK” position. The neutral slide pin should be locked in place by the pin latch. Use an extra-length Allen set screw wrench to adjust the stop screw until the screw just touches the nose of the actuator lever. The screw should not move the lever, but merely touch it.

Then, turn the screw in an additional $\frac{1}{4}$ to $\frac{1}{2}$ turn. Hold it there and tighten the locknut to 15-25 inch-pounds torque.

An alternate method of adjusting the parking lock lever stop is as follows. With the lock lever in the “PARK” position, there should be .005- to .015-inch clearance between the neutral slide pin and the

nose of the actuator lever. A shim can be used to determine the clearance. If the clearance is not correct, it may be adjusted by slightly bending the slide adjacent to the pin location. Be sure to use two pairs of pliers to bend the slide to avoid distorting the slide.

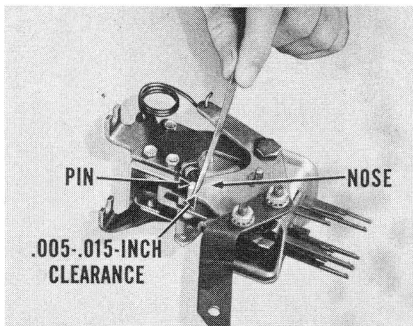

CONCLUSION

By closely following the adjustment procedures on operating controls, as given in this Reference Book, you can quickly build up owner confidence in your ability as a Master Technician. Anything that you can do to save your customer time and needless expense pays off in an increase in steady service customers.

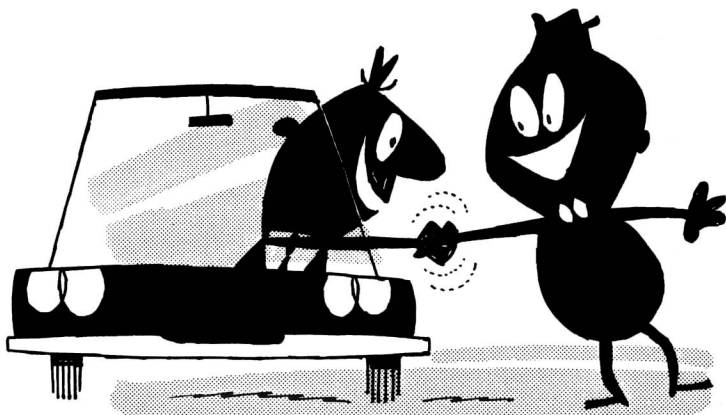

**RECORD YOUR ANSWERS
TO THESE QUESTIONS
ON QUESTIONNAIRE NO. 157**

Adjusting the operating controls will frequently correct a malfunction of a unit. 1

RIGHT

WRONG

The TorqueFlite transmission pushbutton cable adjusting wheel should be turned up tight against the face of the case. 2

RIGHT

WRONG

When adjusting the throttle linkage on automatic transmissions, the throttle valve lever should be moved all the way forward. 3

RIGHT

WRONG

The angle of the floor-mounted gearshift lever on Valiant, Lancer and Chrysler 300-G models, can be changed to suit the individual owner. 4

RIGHT

WRONG

On floor-mounted gearshift control linkage, preset the length of the second-and-high shift rod before adjusting the low-and-reverse shift rod. 5

RIGHT

WRONG

The clutch release fork free play on all models is $\frac{5}{32}$ inch. 6

RIGHT

WRONG

The use of a torque wrench to adjust power steering pump belt tension is optional. 7

RIGHT

WRONG

Rear-wheel parking brakes on Valiant and Lancer models now have only one adjustment point. 8

RIGHT

WRONG

When adjusting the transmission parking brake cable, place the parking lever in the "Park" position. 9

RIGHT

WRONG

If the transmission parking brake cable adjustment is ineffective, the pushbutton housing should be removed for tests and adjustments. 10

RIGHT

WRONG