

SERVICE REFERENCE BOOK

# SERVICING THE 1955 COAXIAL POWER STEERING UNIT



*Prepared by*

**CHRYSLER CORPORATION**  
PLYMOUTH • DODGE • DE SOTO  
AND CHRYSLER DIVISIONS  
**SESSION NO. 87**

Copyright 1955  
Chrysler Corporation

# TECH SEZ:



## "KNOW ALL THAT'S NEW ON POWER STEERING!"

Take a tip from me, fellows . . . power steering's almost everywhere! That's why you'll want to know what's what on our 1955 coaxial units.

When we can service them so all of our owners enjoy the smooth performance built into it, we're bound to maintain our power steering leadership. And now that you may find power steering on any one of our '55 cars, it's especially important to be well-informed.

Here's where you'll find servicing and adjusting pointers you can use:

<b>POWER STEERING AVAILABLE ON ALL MODELS</b> . . . . .	3
<b>ALIGNMENT</b> . . . . .	4
<b>PUMP AND RESERVOIR</b> . . . . .	6
<b>ADJUSTING PROCEDURES</b> . . . . .	6
<b>BACKLASH</b> . . . . .	7
<b>WORM SHAFT BEARINGS</b> . . . . .	10
<b>CONTROL VALVE</b> . . . . .	11
<b>CONTROL VALVE ADJUSTMENT—1954 MODEL</b> . . . . .	15
<b>REPLACING SEALS AND "O" RINGS</b> . . . . .	16
<b>CHECKING PUMP PRESSURE</b> . . . . .	18
<b>INTERNAL SEALS AND "O" RINGS</b> . . . . .	19
<b>SERVICING INSTALLED UNIT</b> . . . . .	21
<b>OTHER POINTS TO KEEP IN MIND</b> . . . . .	25
<b>CONCLUSION</b> . . . . .	27

# POWER STEERING

## AVAILABLE ON ALL MODELS

There are two models of power steering units available. One is on the Plymouth and Dodge. The other's on De Soto and Chrysler cars.

And in its price class, Plymouth and Dodge are the only cars with an integral-type, full-time power steering unit. Just as a reminder . . . this gear has all parts except the pump and reservoir located around a common axis. That's why it's called *coaxial* power steering.

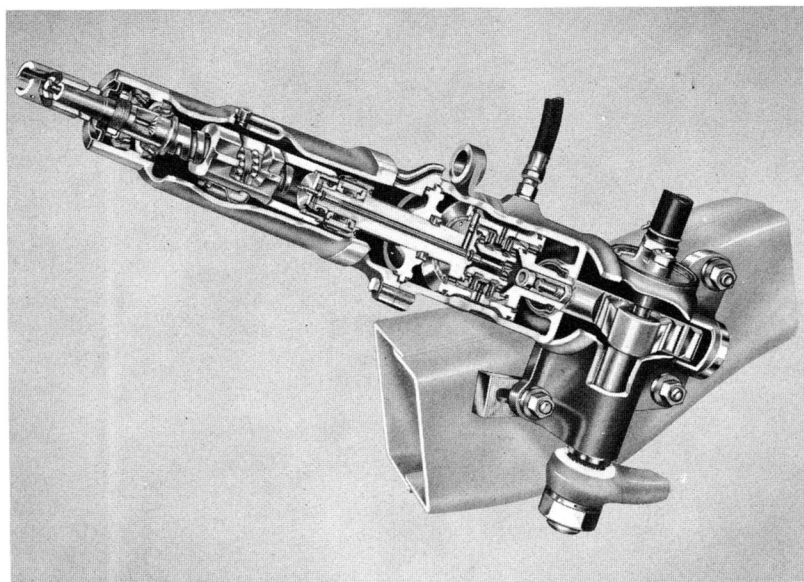

So, real history is being made in power steering. Many competitive cars still use linkage-booster type units. That puts us way out in front with the best, but also calls for keeping our service in step with these advances.

# ALIGNMENT

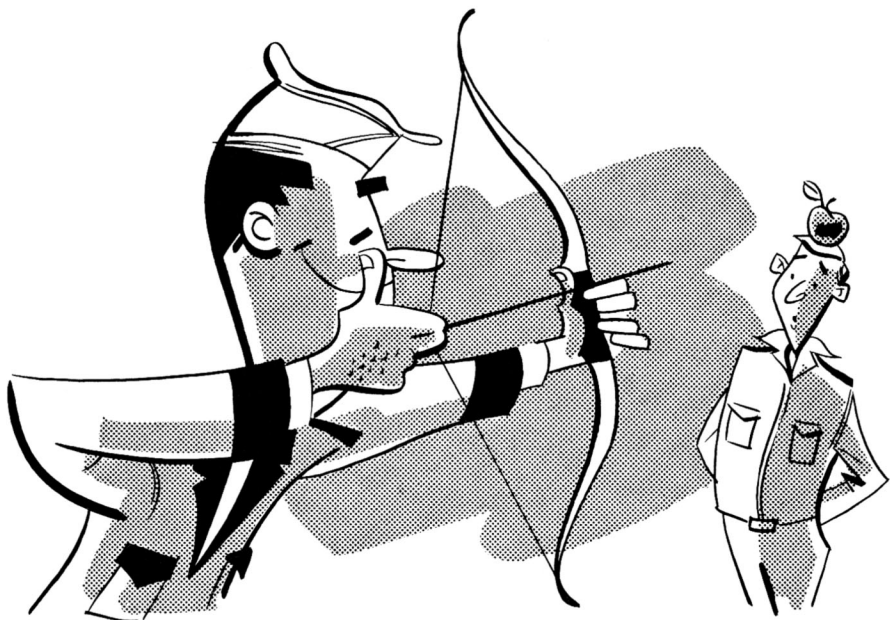

You're going to like the new power steering unit. Servicing and adjusting procedures have been made easier to do.

Take the new method of mounting, as an example.

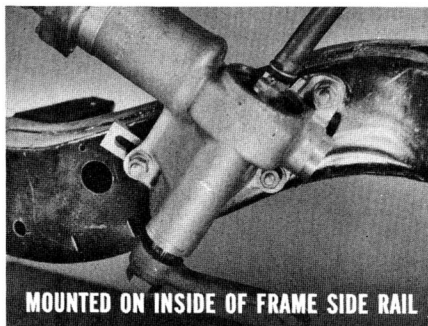

You'll notice that it's mounted on the *inside* of the frame side rail. This is a very sturdy setup, and much easier to line up whenever necessary.

To align the gear in the car, here's all you have to do. Just loosen the three mounting bolts and the instrument panel clamp bracket. This allows the column to align itself, because of the swivel washers between the housing and the frame. Then tighten the steering column clamp bracket.

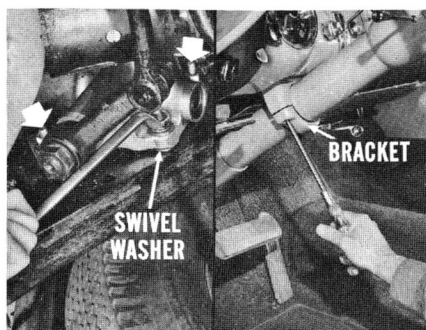

Next . . . tighten the two front bolt nuts to 20 foot-pounds. Don't tighten the rear bolt nut at this time.

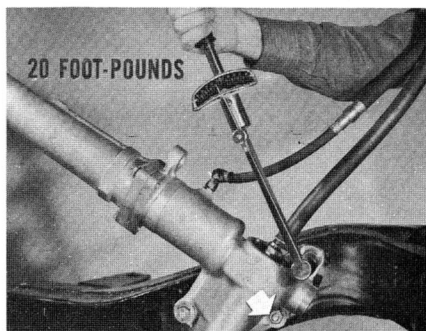

Now, install the tapered wedge between the frame side rail and gear housing at the rear bolt. Tap it lightly into place, and be sure the wedge is parallel to the centerline of the steering column. If it isn't, you may snap the mounting lug off the gear housing when you tighten the nut.

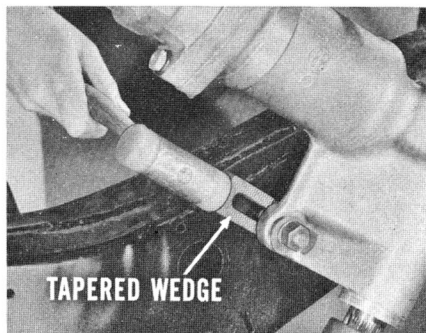

Finally, tighten all three retaining bolt nuts to 50 foot-pounds. Lining up the steering gear in this way will do away with any strain on the housing between the frame and instrument panel.

## PUMP AND RESERVOIR

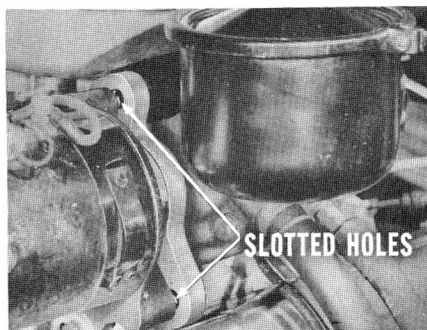

There's a new reservoir and both the oil pump and reservoir have new mountings. The oil pump mounting has this adjustment feature. The two holes are *slotted* so you can move the pump through an arc to secure proper leveling of the reservoir. In addition . . . the pump mounting bolts are easily accessible. You can reach them with a socket wrench.



You should check oil level in the reservoir every 1000 miles, or 30 days. But before you make this check, always wipe off the cover. You know what dirt in the oil can do. The oil level should be up to the top of the filter. Add automatic transmission fluid, type "A", whenever it's needed.

## ADJUSTING PROCEDURES



Before going into a need for servicing or adjustment, remember that front wheel alignment, proper lubrication, and correct tire pressure are important as ever. Power steering isn't going to cover up the need for any of these control factors.

After checking the front end, you're ready to go into a steering adjustment. The kind of adjustment, of course, depends upon what condition you're trying to correct. So, let's consider those conditions that may indicate the need for specific adjustment.

**BACKLASH ADJUSTMENT.** Suppose you came across an occasional case where an owner reported that the front wheels would sometimes



tend to wander. "Nothing too serious," he might say, "just enough to make me move the steering wheel all the time in order to keep the car going straight ahead."

In a case like this, you should check backlash between the teeth of the rack and sector gear. You can do this with the gear in the car.

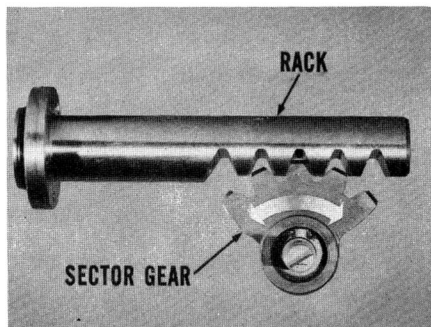

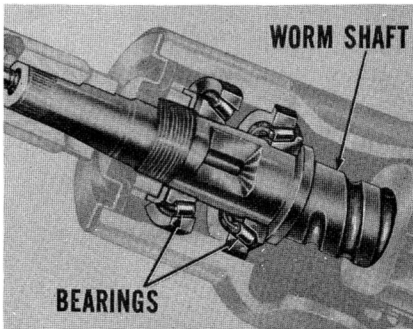

If backlash is found to be up to specifications, your next step will be to check the worm shaft bearing adjustment. There should be no end play in the worm shaft.

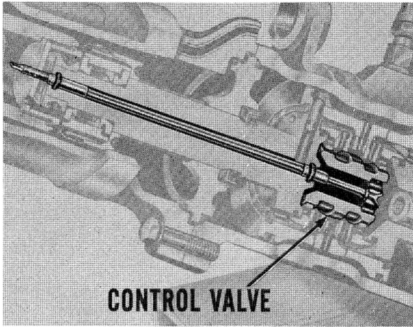

Finally, you'd check the adjustment of the control valve, which can also be done with the unit in the car. But, if none of these three adjustment checks uncovered anything off the beam, you'd then suspect something out of order on the inside. That, naturally, would call for taking the unit out of the car and making an internal inspection.

In general, then, always check backlash between the rack and sector gear teeth *before* you make any other adjustment on the coaxial unit. If backlash isn't right, no amount of control valve adjusting will do any good.

To adjust for backlash, remove the steering arm from the gear shaft, and temporarily install another arm. Turn the steering wheel from one extreme to the other and count the number of turns. You'll count about  $3\frac{3}{4}$  turns.

With the wheel at one end of its travel, turn it back about  $1\frac{7}{8}$  turns, or to the center position. This will place the steering gear arm in the straight-ahead position.



Back off the adjusting screw in the end of the housing cover until backlash can be felt at the gear arm. Then turn the adjusting screw in until all backlash is removed. From this point, turn the screw in three-quarters of a turn. This will place a preload on the gear teeth and enable them to retain a no-backlash condition throughout the normal steering range.

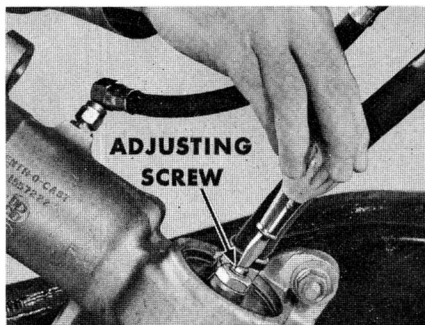

A further check to be sure the gearshift is properly centered in the rack teeth can be made by turning the steering wheel (or coupling, if the wheel has been removed). Keep checking for backlash at the steering gear arm until backlash can be felt. Note the distance backlash appears on each side of the straight-ahead position. It should be at approximately the same point. If it isn't, remove the coupling and reposition it on the shaft so the point at which backlash can be felt is the same distance on each side of the straight-ahead position.

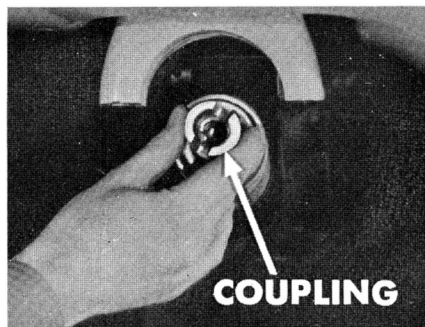

**WORM SHAFT BEARING ADJUSTMENT.** If the worm shaft bearings are *adjusted too loosely*, you'll notice the extra end play in the steering gear. You'll be able to move the steering wheel up and down on the end of the steering col-

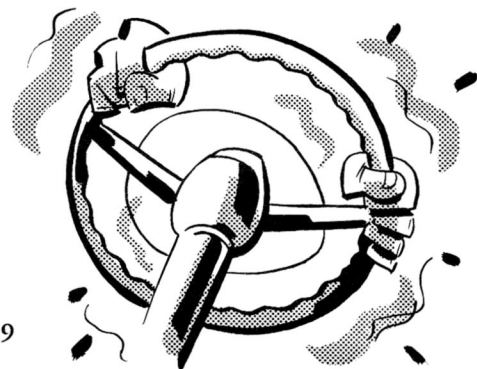

umn. This free play, of course, will let the control valve move out of position in relation to the piston. The owner will notice it as a tendency to wander and he'll find himself continually moving the steering wheel to keep the car going straight ahead.

Now, if the bearings are *adjusted too tightly*, valve action in the gear will be too stiff. Steering will be easy in one direction and hard in the other. An owner might refer to it as "poor returnability." These bearings, as you probably know, are the tapered-roller type which call for a definite preload to be correctly adjusted.



To adjust the bearings properly, remove the coupling screw first. Then, insert the Wedge (C-3392) between the lower end of the coupling and the worm housing oil seal. Strike the wedge firmly several times to remove the coupling from the tube.

Next, remove the worm housing seal from the housing and worm shaft. Use a screwdriver as a wedge between the seal's metal lip and the housing. Lift off the seal. Then, by bending down the tang, unlock the bearing adjusting nut lockwasher. One tang locks the nut in place.

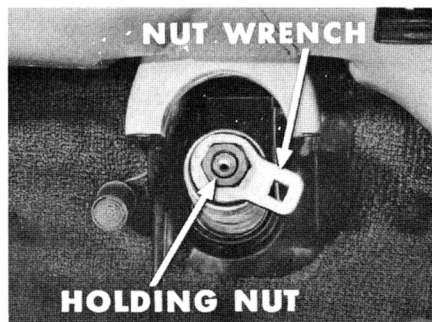

Now, place the Worm Adjusting Nut Wrench (C-3320) over the worm shaft followed by the Holding Nut (C-3319). Then, using a torque wrench on the holding nut, turn the worm shaft counterclockwise until you read 20 foot-pounds against the inner bearing. This will properly preload the bearing so that it's correctly seated.

Holding the worm shaft at 20 foot-pounds, attach another torque wrench to the adjusting nut wrench. Tighten the adjusting nut to 15 foot-pounds. Make sure the bearings are seated properly by rotating the worm shaft several times.

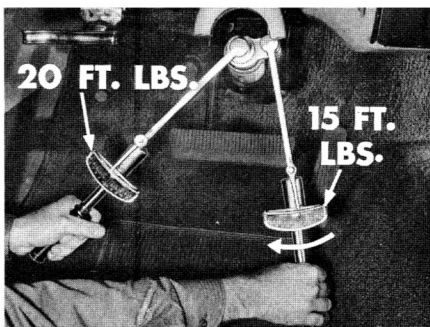

After that, loosen the adjusting nut. Then, using the holding nut with a torque wrench, hold the worm shaft against the bearing at 5 foot-pounds in a counterclockwise rotation. Retighten the adjusting nut to 5 *inch-pounds*.

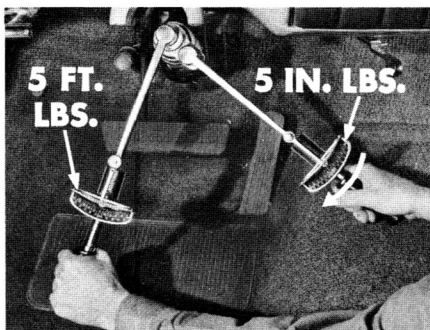

Finally, lock the adjusting nut in place by bending one tang of the lockwasher into a slot of the nut. Reverse the plate of the Installing Tool (C-3322), and drive in the worm bearing oil seal (lip inward) until it seats against the worm housing. Once you're sure your bearing adjustment's right, you can go ahead with other necessary adjustments, such as centering the control valve in its piston.

**CONTROL VALVE ADJUSTMENT.** Suppose an owner reports a case where the steering's too easy in one direction . . . and too hard in the other. He might call it plain hard steering, or poor returnability. An occasional report of this kind probably means that the control valve isn't centered in its piston. You already know that the control valve

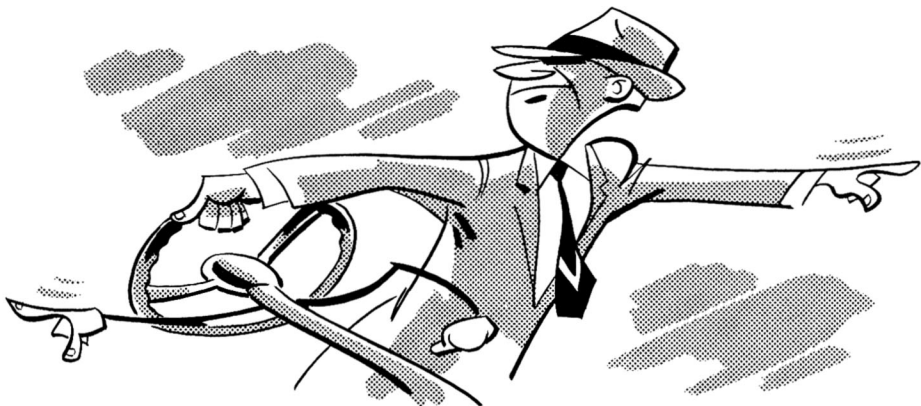

must be centered in the piston so the car will steer a straight course, and respond properly to turning in both directions. When the control valve is properly centered, it permits an equal flow of oil to both ends of the piston so that no steering movement is obtained until called for by movement of the steering wheel.

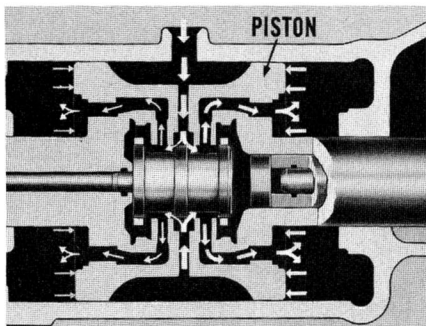
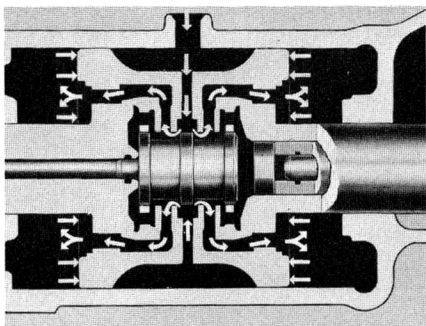

If the valve isn't centered, more pressure is applied to one end of the piston than to the other. So, the front wheels try to turn in one direction or the other.

To correct for that condition, you'll have to adjust the control valve, an operation you now can do while the unit's on the car. So, remove the steering wheel, then the upper jacket and steering tube. Then, remove the coupling retaining screw in the end of the worm shaft. That will give you access to the control valve rod.

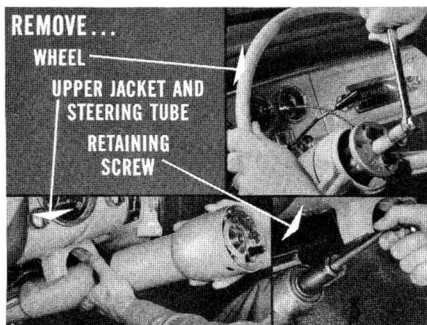

Next, disconnect the steering linkage by using the puller to remove the steering arm from the gear shaft. *Always* use the puller so you won't damage the gear shaft or bearings.

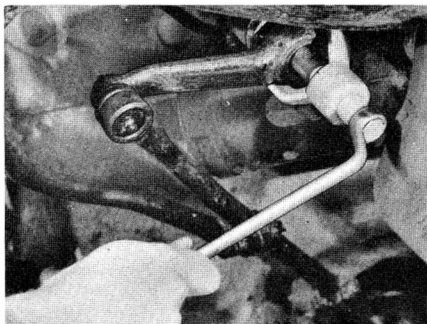

For adjustment purposes, then, temporarily install another steering arm on the gear shaft. Tighten the arm nut to 100 foot-pounds.

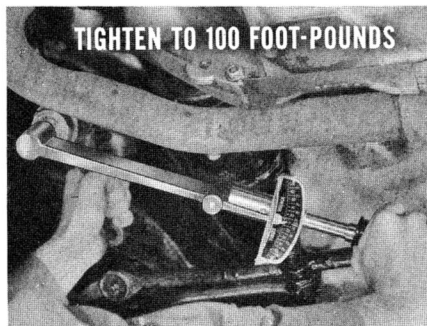

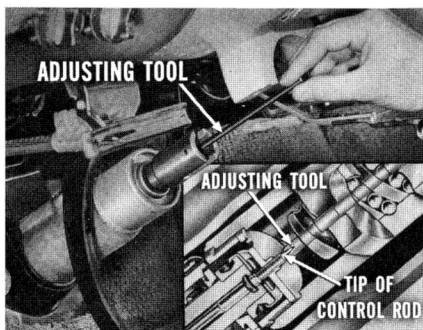

Now, insert the Control Valve Adjusting Tool (C-3445) through the center of the worm shaft and onto the tip of the control valve rod. Tap it down lightly to make a firm connection. Then, start the engine, and let it warm up to normal operating temperature.

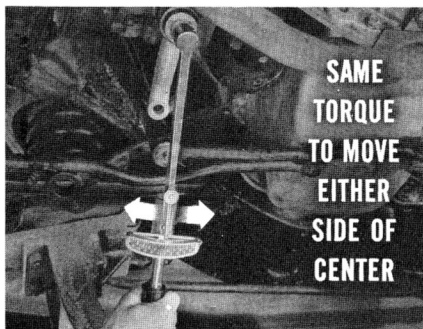

With the steering arm in *straight-ahead position*, see if it takes the *same torque* to move the gear shaft to either side from the center position. It should require equal torque.



If the torque is different, turn the control valve adjusting tool to make torque equal. But be careful. A little movement of the valve tool goes a long way.

**CONTROL VALVE ADJUSTMENT ON 1954 MODEL.** While we're on adjustments, centering the control valve on 1954 model units used on Chrysler and De Soto cars has also been made easier to do. Remove the unit from the car. Take it to the bench and hook it up to either a bench pump setup or to the pump on the engine. Then, make sure that backlash is properly set.



Next, remove the coupling, oil seal, worm bearing adjustment nut and washer. Remove the upper worm bearing from the housing and shaft. Then, remove the three housing bolts and nuts and lift it off the worm housing. Remove the ball guide from the worm connector.

Now, turn the worm out of the connector, being careful to catch the balls as they come out of the connector. You should account for 40 balls.

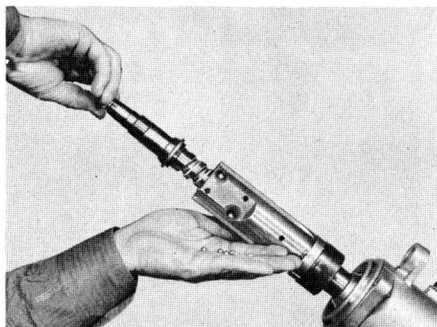

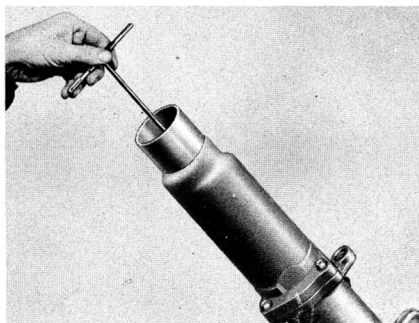

Insert the adjusting tool through the connector and tap it into place on the tip of the valve rod. Start the engine. Using the Torque Wrench (C-3005) with a suitable socket on the steering gear arm nut, check torque needed to turn the gear shaft from one extreme

of its travel to the other. When the control valve is properly centered, the torque should be the same in either direction.

If readings are different, turn the adjusting tool until you get equal torque on either side. Again, move the tool only slightly, as only a little adjustment is required to get the desired equal torque.

*CAUTION: When removing the adjusting tool, be careful not to move the valve and upset your adjustment.*

## REPLACING SEALS AND "O" RINGS

When you go about checking for an occasional report of an oil leak, be sure to keep in mind the difference between oil *leakage* and oil

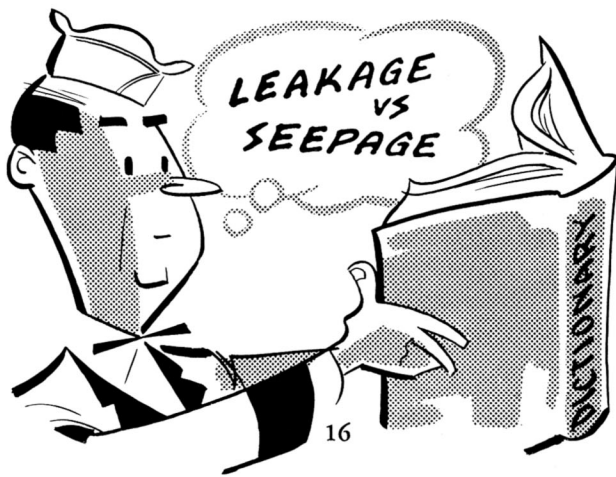



*seepage*. An oil spot on the driveway, or drops on the outside of the gear housing, doesn't necessarily mean there's an oil leak in the power steering unit. The only real way to tell whether it's seepage or leakage is to find out whether the owner has had to add oil to reservoir repeatedly to keep the level up where it belongs. This is *leakage*.



You might ask, "What about occasional cases where oil is noticed coming from between the worm and gear housings?" Even this isn't necessarily leakage. It may be strictly the result of a normal flexing of the housings due to momentary high pressure in the hydraulic system.

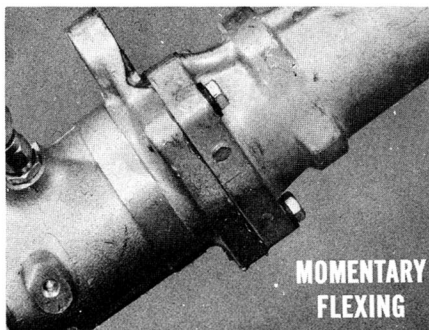

Sometimes the worm housing gets overfilled with fluid to the point where some of it works out the vent hole. Again, this may only be oil seepage. In each case, check to see if the owner has had to have fluid added several times before you start looking for oil leak causes.

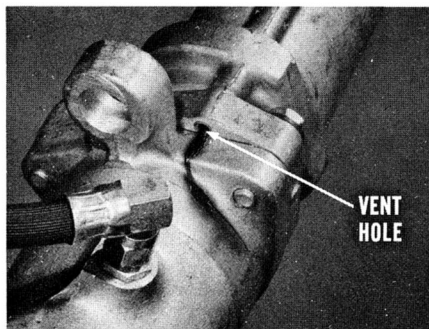

## CHECKING PUMP PRESSURE.

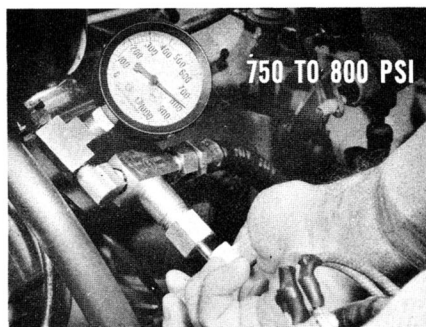
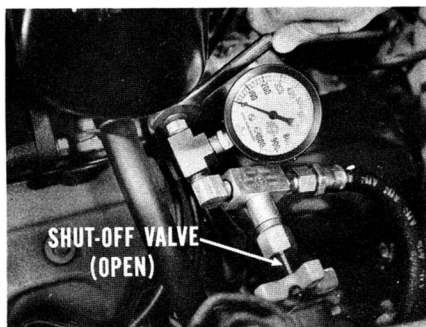

*CAUTION: Make these high-pressure tests carefully. Don't leave that shut-off valve closed more than a few seconds at a time, or you'll heat up and damage the pump.*

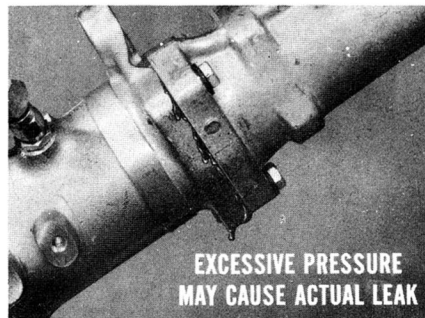

Now, when you are sure that there is a leak in the unit, you should check pump pressure to see if extremely high pressure might have been the cause. So, with the reservoir filled to its proper level, install a pressure gauge with the shut-off valve open. Start the engine and let it warm up properly.

What you want to do is check maximum pressures in the hydraulic system. For one thing, you want to know what pressure the pump will develop. So, close the shut-off valve in the gauge for a few seconds, with the engine running at idle speed. The pressure should immediately go up to between 750 and 800 psi—but no higher.

Another thing, never run a test with the engine speed higher than 1500 rpm. At that speed, the pressure may go up to about 900 psi. The harm in too high a pressure is that it may flex the housings even more than normal and cause an actual leak instead of only seepage.

If the pressure goes higher than 900 psi at 1500 rpm, you'll have to replace the flow and relief valve assembly.

Now, if there is a leak that allows pressure to force oil out of the vent hole in the worm housing, you'll have to remove the unit for disassembly.

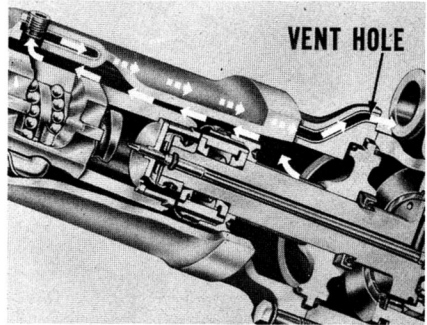

**INTERNAL SEALS AND "O" RINGS.** There are three points where oil could get by and up into the worm housing: First, at the "O" ring on the upper end of the control valve rod; second, at the reaction valve control spacer seal; third, at the housing head oil seal.

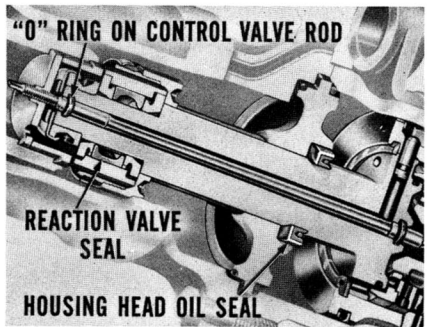

Whichever point is allowing oil to get past is not the only seal you'd replace when you reassemble the unit. No siree! Whenever you have a power steering unit disassembled, replace *all* the seals and "O" rings. Why take chances? Just one leak, and you'd have to do the job over. So, play it safe and install new seals throughout.





One important thing to keep in mind is initial lubrication of new "O" rings and seals before you install them. Always coat them with MoPar Lubriplate first. It prevents damage to the seal and makes installation a lot easier.



If you ever have to replace the reaction control valve spacer seal, there's an *improved* seal available. It has a silver-colored "M" on the outside diameter. This is the *only one* you should use.

Actually, we'd all be way ahead if everybody would scrap the old type reaction control valve spacer seals. Nobody should use anything but the seal with the silver "M".

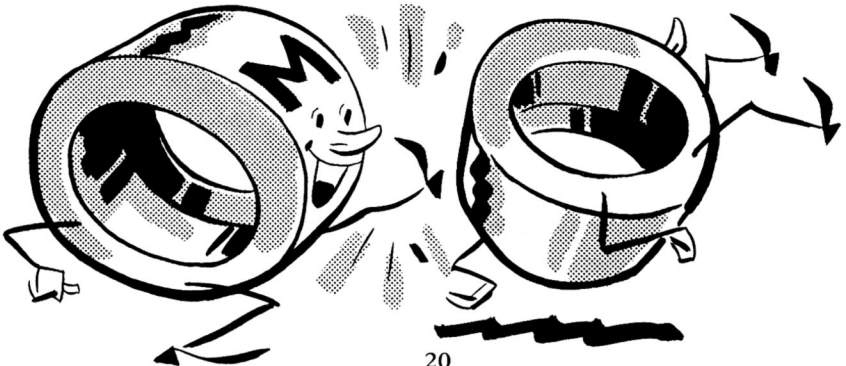

**SERVICING INSTALLED UNIT.** There are some points of possible leakage that you can correct while the unit's on the car.

**Gear Housing Cover "O" Ring (Plymouth and Dodge)**—Take the gear housing cover "O" ring on the Plymouth and Dodge as an example. In a case of this kind, first wipe off all the dirt from the cover area. Then, remove the lock nut from the gear shaft adjustment screw. Next, remove the snap ring.

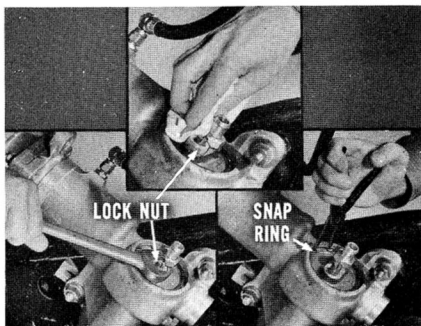

Turn the screw *into* the cover to raise the cover. Hold the cover level as you turn the screw to keep it from cocking in the housing. Finally, lift out the cover and remove both the cover "O" ring and the "O" ring from the adjusting screw.

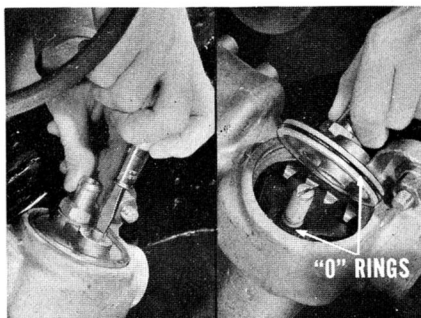

When you install a new "O" ring on that screw, use the Thread Protector (C-3401) to keep the "O" ring from being chewed up. Also, coat the ring with MoPar Lubriplate. Just roll the "O" ring over the protector and into the groove in the screw. Finally, remove the protector.





Coat the new cover "O" ring and place it in the groove in the cover. Install the cover by turning the adjusting screw into it. Remember to keep tapping the cover lightly. That keeps it lined up and allows it to be forced into the housing. When the cover is seated, install the snap ring with the tapered side up.

**Gear Housing Cover Gasket (Chrysler and De Soto)**—The cover in



this case is held by three cap screws and lockwashers. Remove these first after you carefully wipe away any dirt in the cover area. Turn in the gear shaft adjusting screw and lift off the cover and gasket. Discard the gasket and the "O" ring on the adjusting screw.

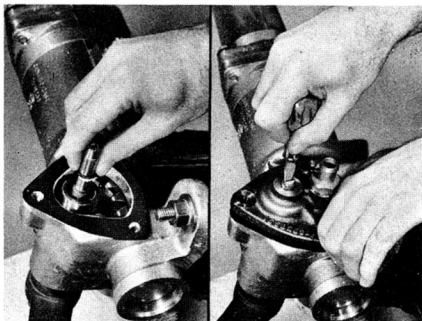

Coat the new gasket with MoPar Lubriplate and install it in place. Install a new "O" ring on the adjusting screw and reinstall the cover. Turn the gear shaft adjusting screw into the cover as far as it will go. This will insure seating the cover on the gasket.

Torque up the cap screws to 30 foot-pounds. And remember . . . you're going to have to readjust the rack and sector backlash before the job is finished.

### Housing End Plug "O" Ring—

To replace this "O" ring, first carefully wipe the lower end of the housing clean. Remove the retaining snap ring next. Then, drill and tap a hole in the center of the plug so you can install a bolt to withdraw the plug. NOTE: Coat the drill with heavy grease to keep the metal cuttings from getting into the housing.

Draw the plug straight out so you won't damage the housing. The "O" ring will come out with the plug and you can discard both parts.

On a new end plug and "O" ring, coat the ring with MoPar Lubriplate and roll it into the groove in the plug. Coat the plug edges with a non-hardening sealer. Insert the plug in the housing and push it into place. Finally, install the snap ring, making sure it is properly seated in its groove.

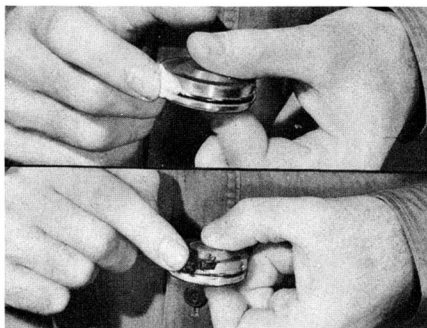

**Gear Shaft Oil Seal**—When you want to replace the gear shaft oil seal, be sure to use the puller to remove the steering arm from the gear shaft. Never use a wedge to remove that arm or you'll damage the gear.

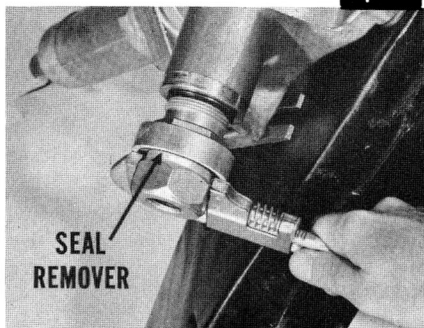
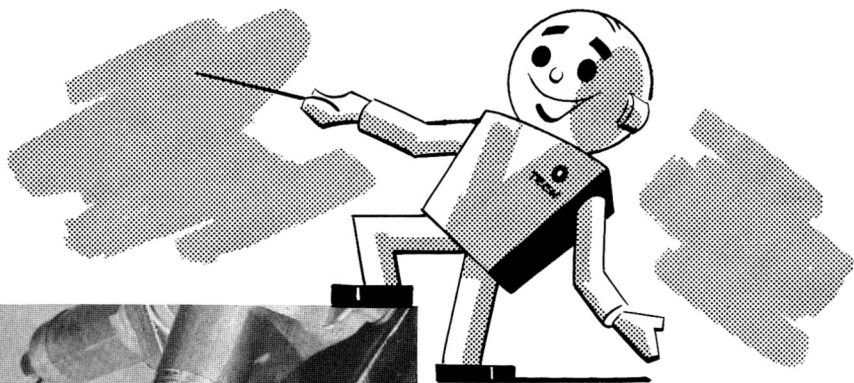

Then remove the lock wire so you can remove the seal by using the Seal Remover (C-3350). Be particularly careful when you install the new seal.

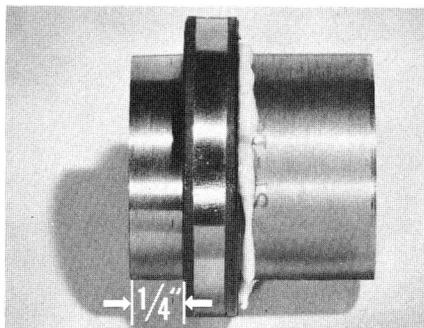

Coat the new seal with MoPar Lubriplate. Place it lip-side down on a piece of clean paper. Install the tapered sleeve end of the Seal Removing and Installing Tool (C-3350) into the seal so the seal is back on the sleeve about  $\frac{1}{4}$ ".



Then, with the lip toward the housing, slide the seal over the shaft end until it contacts the counterbore. Install the tool adapter over the sleeve and push the seal into position. Install the tool coupling nut over the shaft threads and turn it until the adapter shoulder contacts the housing.

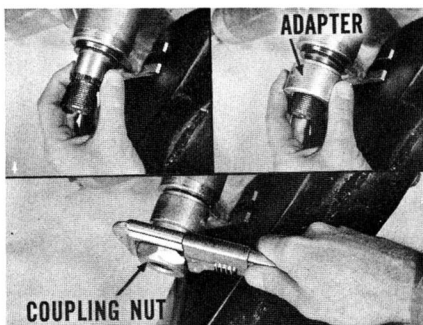

Then, remove the nut and adapter. Wrap the sleeve with tape so you can get a good grip on it. Twist it and remove it from the shaft. Install the lock wire, then the steering arm, washer and nut. Tighten the nut to about 100 foot-pounds.

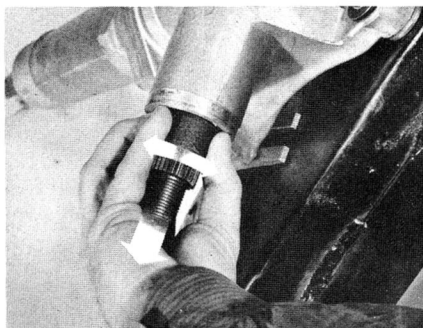

## OTHER POINTS TO KEEP IN MIND

High pressure alone doesn't necessarily cause oil leakage. There might be foreign matter under an "O" ring, the "O" ring or seal might have been cut or twisted during installation, or metal surfaces being sealed could be scratched or nicked.

Take the flanges of the housings, for example. If your inspection shows them to be scratched, nicked, or rough, smooth them up with a stone or with crocus cloth. And always clean sealing surfaces carefully.



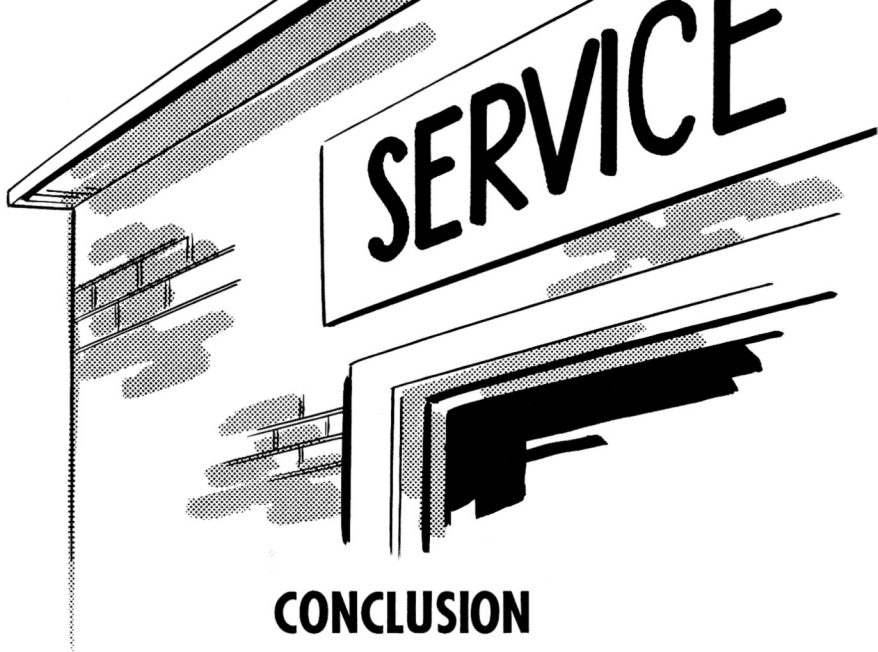

## CONCLUSION

Do a thorough job of servicing the coaxial power steering unit. That's how to be sure the unit will continue to perform satisfactorily, and give your customers pleasure. When you are in a position to give prompt and efficient service for all your customers' requirements you won't need to worry about service volume. Customers will not only continue doing business with you, but they'll recommend your service department to their friends and neighbors.

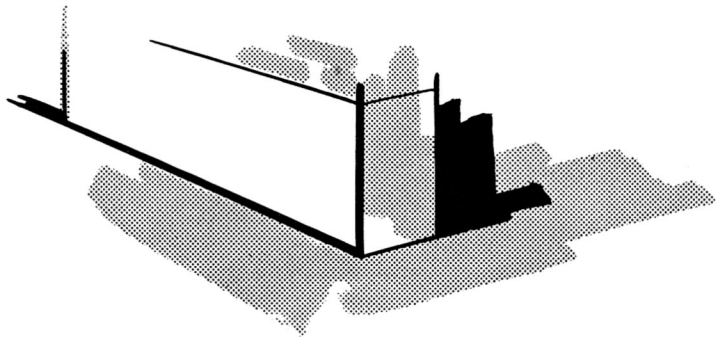

**RECORD YOUR ANSWERS  
TO THESE QUESTIONS  
ON QUESTIONNAIRE NO. 87**

On the 1955 unit, the center of the worm is drilled out for its full length, giving room to use a new control valve adjusting tool.

RIGHT

1  WRONG

The oil pump mounting holes are slotted so you can move the pump through an arc to secure proper leveling of the reservoir.

RIGHT

2  WRONG

If front wheels tend to wander, check backlash, worm shaft bearing and control valve adjustment in that order.

RIGHT

3  WRONG

The control valve must be properly centered in the piston so the car will steer straight and respond correctly to turning in both directions.

RIGHT

4  WRONG

With the steering arm in straight-ahead position, it should take equal torque to move the gear shaft either side of center.

RIGHT

5  WRONG

Sometimes a gear housing is overfilled with fluid and some of it works out of the vent hole giving the appearance of a leak.

RIGHT

6  WRONG

If pump pressure goes higher than 900 psi at 1500 rpm, replace the flow and relief valve assembly.

RIGHT

7  WRONG

Pressure oil can get up into the worm housing past one of three places: the "O" ring on the upper end of the control valve rod; the reaction valve control spacer seal; and the housing head oil seal.

RIGHT

8  WRONG

When you have a power steering unit disassembled, replace only those seals and "O" rings which show damage.

RIGHT

9  WRONG

The reaction control valve spacer seal, identified by a silver-colored "M", should always be used for replacement.

RIGHT

10  WRONG